

A trajectory of change in stone-tool technologies reveals that stasis typifies much of the prehistory tool record, until relatively recent times.

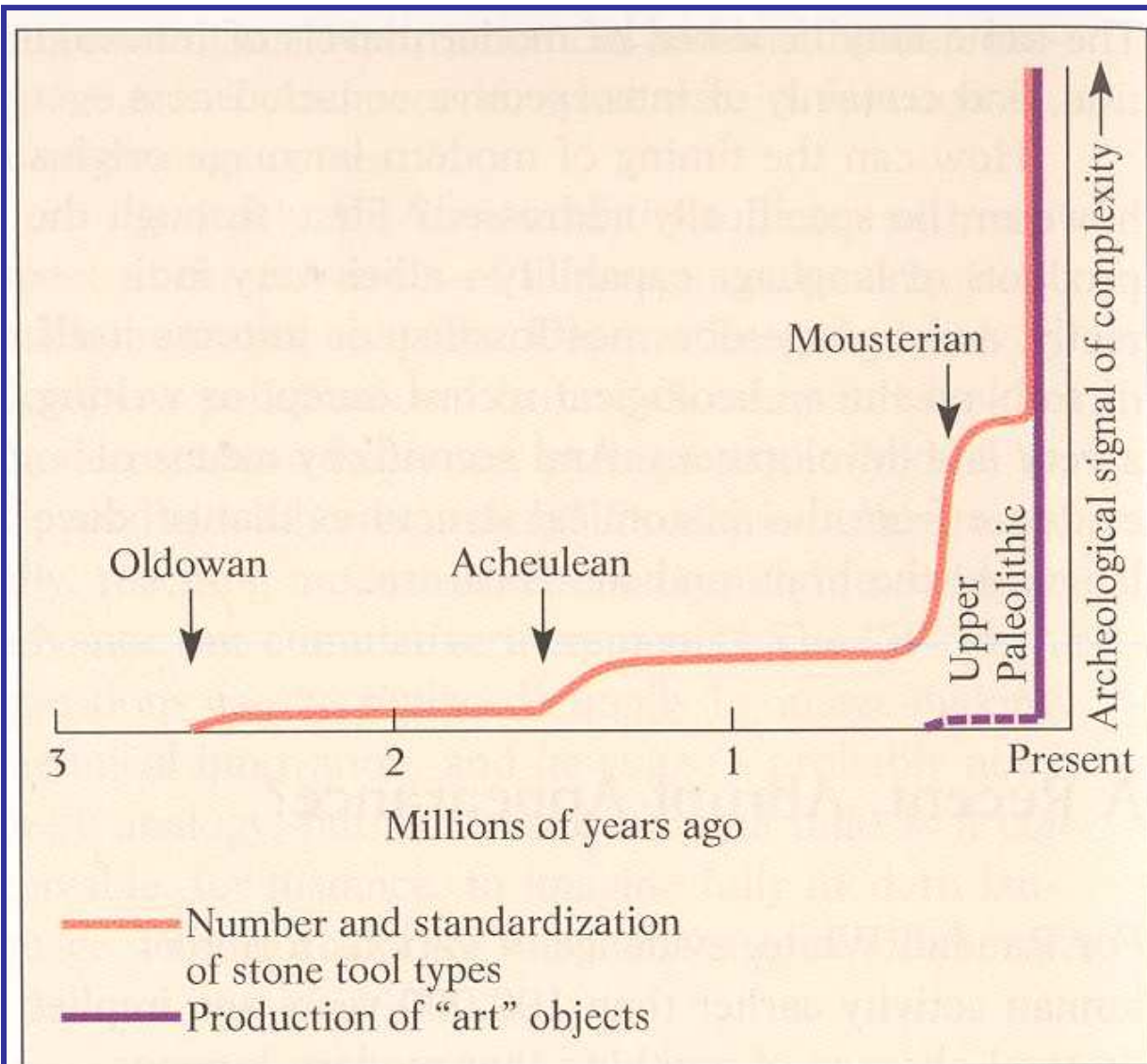

If the complexity of the archeological record may be taken as a guide, language capacity arose late in hominid pre-history.

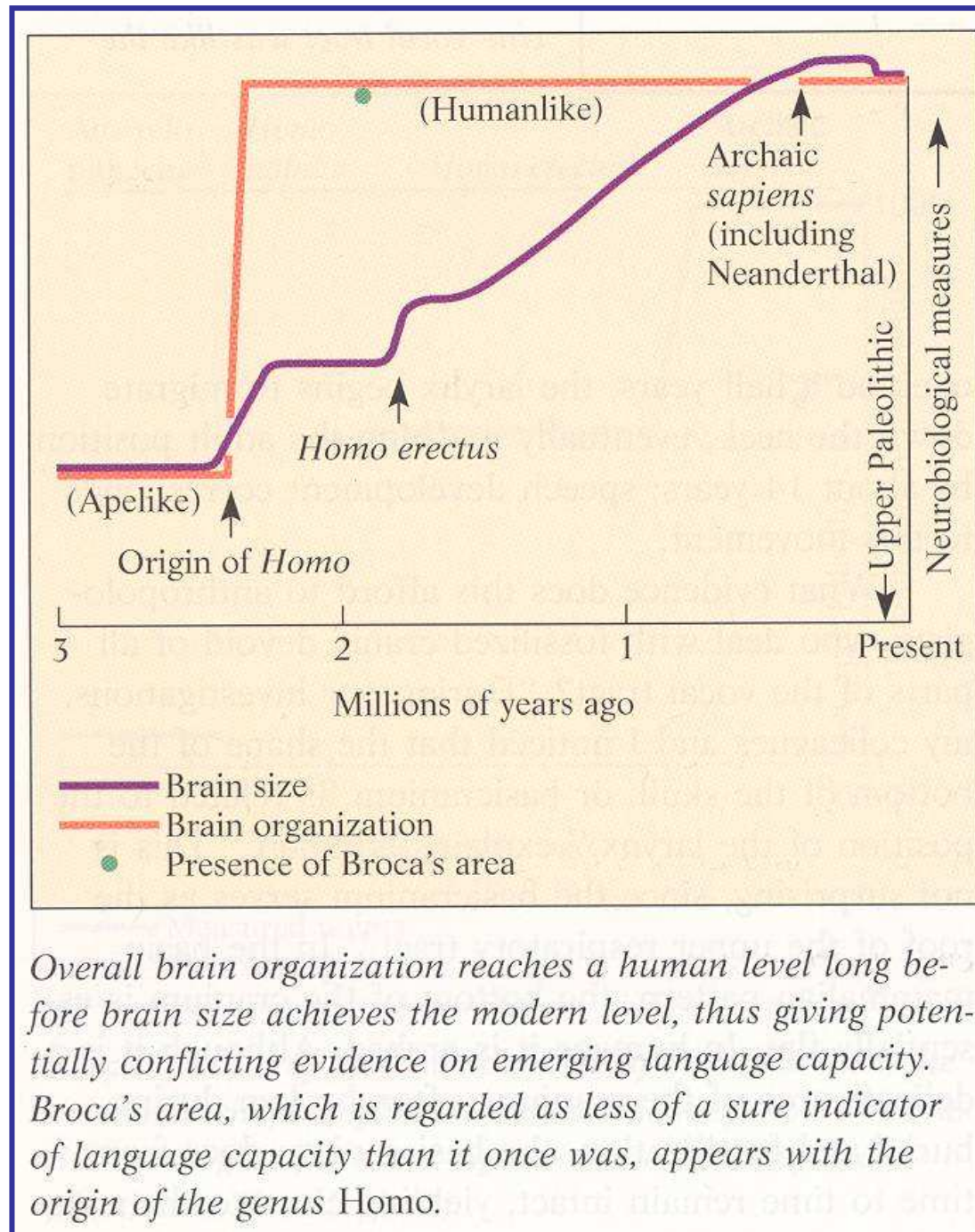



It sounded like a dream
assignment for any researcher,
thought Susan Blackmore...

Hello, who are you?



MICHAEL NICHOLS National Geographic Image Collection

Today's Lesson includes a demonstration of how to crack open a coula nut. A mother chimpanzee in the Tai Forest of Ivory Coast uses a stone hammer to cleave a nut while a youngster watches. Not all chimpanzees in this area have developed this behavior: on the eastern bank of the Sassandra-N'Zo River, chimpanzees do not crack nuts even though members of the same species on the other side of the river, just a few miles away, do. All the required raw materials are available on both sides, and the nuts could be cracked using the technique habitual at Tai. The river serves as a literal cultural barrier.

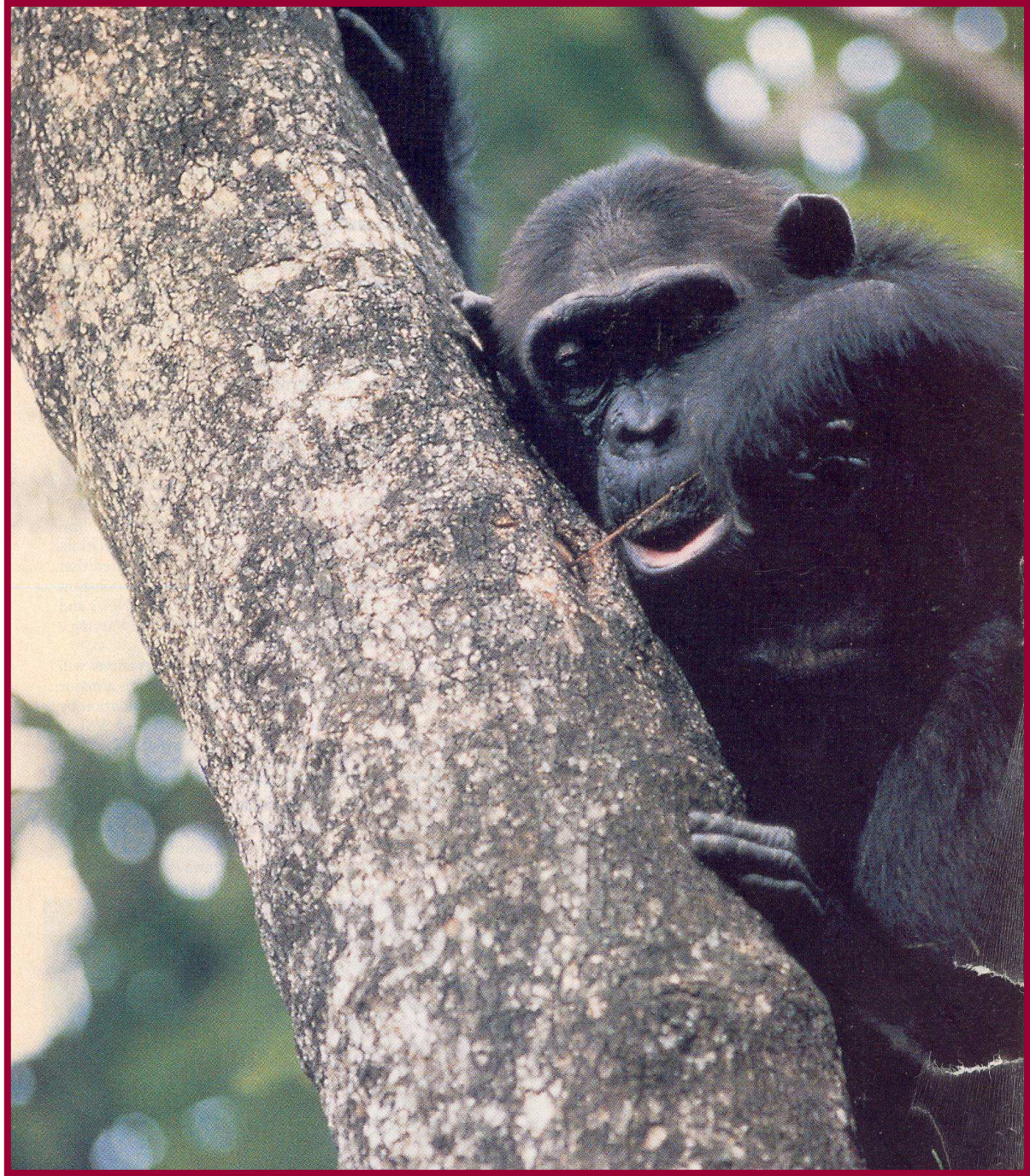

Smarter Than Anyone Thought

Scientists have challenged the 19th-century view that areas of the brain needed for cognitive behavior did not evolve in birds and that their behavior was based largely on instinct.

OLD VIEW OF BRAIN

It was thought that most of the cerebrum consisted of cells packed in clusters associated with instinctive behavior and that evolution did not provide the layers of flat cells, typical of mammals, needed for complex behavior.

- Associated with cognitive behavior
- Associated with instinctive behavior

CEREBRUM

CELL CLUSTERS



NEW VIEW

It is now believed that the bird's cerebrum is like that of a mammal. Complex behavior, like tool use or vocalization, arises from the interaction between higher and lower regions.

- Generates cognitive behavior
- Coordinates cognitive behavior

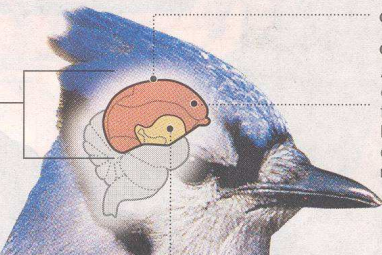

CEREBRUM

CELL CLUSTERS

A large area of cell clusters function in layers of flat cells in mammals

Interacts the higher region to produce complex behavior.



Photo illustration based on photo by Tom Vezo/Vireo

HOW HUMANS COMPARE

The human brain is structured so that layers of flat cells on top interacting with clusters of cells below are responsible for complex behavior.

FLAT CELL LAYERS

Songbird brain to scale

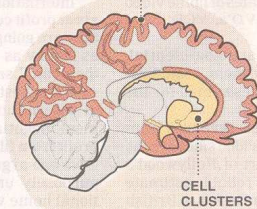

CELL CLUSTERS

(Πλάτωνος "Πρωταγόρας")

321c	Προμηθεύς ορά τον άνθρωπον γυμνόν τε και ανυπόδητον και άστρωτον και άοπλον	Η ΑΝΑΓΚΗ
	κλέπτει την έντεχνον σοφίαν σύν πυρί	ΤΕΧΝΟΓΝΩΣΙΑ ΕΝΕΡΓΕΙΑ

322a	και εκ τούτου ευπορία μεν ανθρώπω του βίου γίνεται	ΕΠΙΒΙΩΣΗ
322b	Εζήτουν δε αθροίζεσθαι και σώζεσθαι κτίζοντες πόλεις	ΚΟΙΝΩΝΙΑ
	ηδίκουν δ' αλλήλους ώστε πάλιν σκεδαν ύμενοι διεφθείροντο	ΑΝ-ΗΘΙΚΟΤΗΣ

322c	Ζεύς Ερμήν πέμπει άγοντα εις ανθρώπους αιδώ τε και δίκην	ΑΕΙΕΣ
322d	Επι πάντα, ου γαρ άν γένοιτο πόλεις ει ολίγοι αυτών μετέχοιεν	ΔΗΜΟΚΡΑΤΙΑ

*Και ελάλησε Κύριος προς Μωυσήν λέγων
Ιδού ανακέκλημαι εξ ονόματος τον Βεσελεήλ (Μππετσαλέλ)
τον του Ουρείου του Ώρ, εκ της φυλής Ιούδα,*

- και ενέπλησα αυτόν πνεύμα θείον σοφίας*
- και συνέσεως και επιστήμης*
- εν παντί έργω διανοείσθαι και αρχιτεκτονήσαι,*
- εργάζεσθαι το χρυσίον και το αργύριον και τον χαλκόν*
- και την υάκινθον και την πορφύραν και το κόκκινον το νηστόν*
- και τα λιθουργικά*
- και εις τα έργα τα τεκτονικά των ξύλων εργάζεσθαι κατα πάντα τα έργα.*







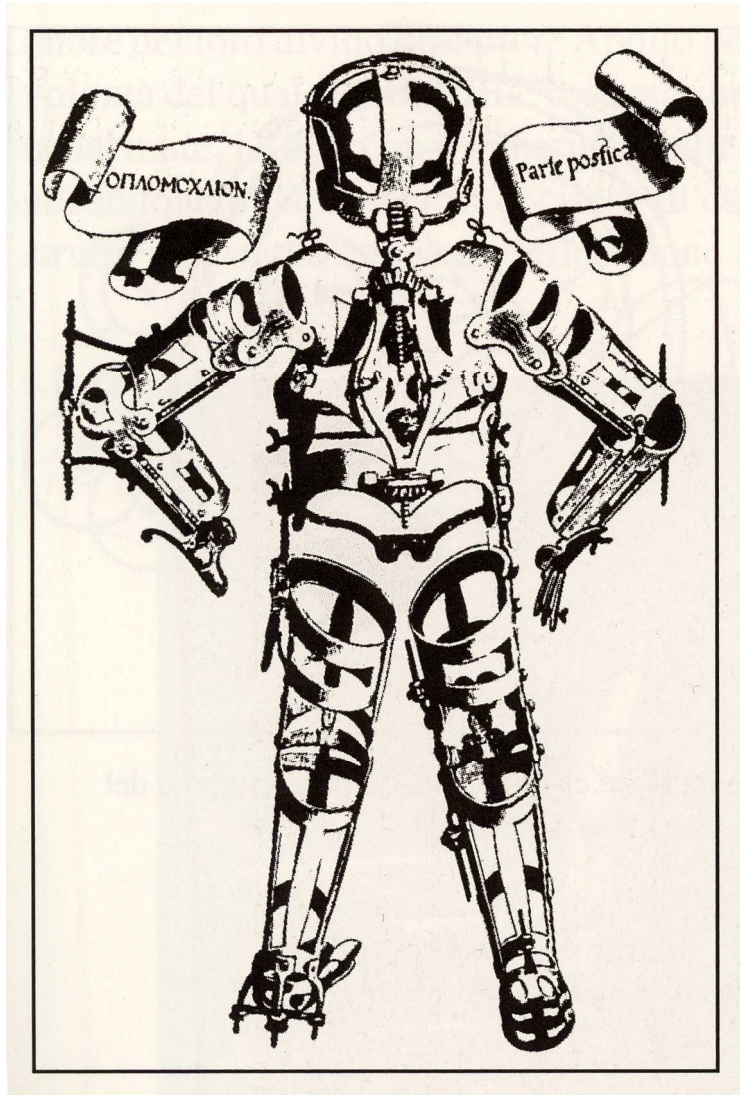





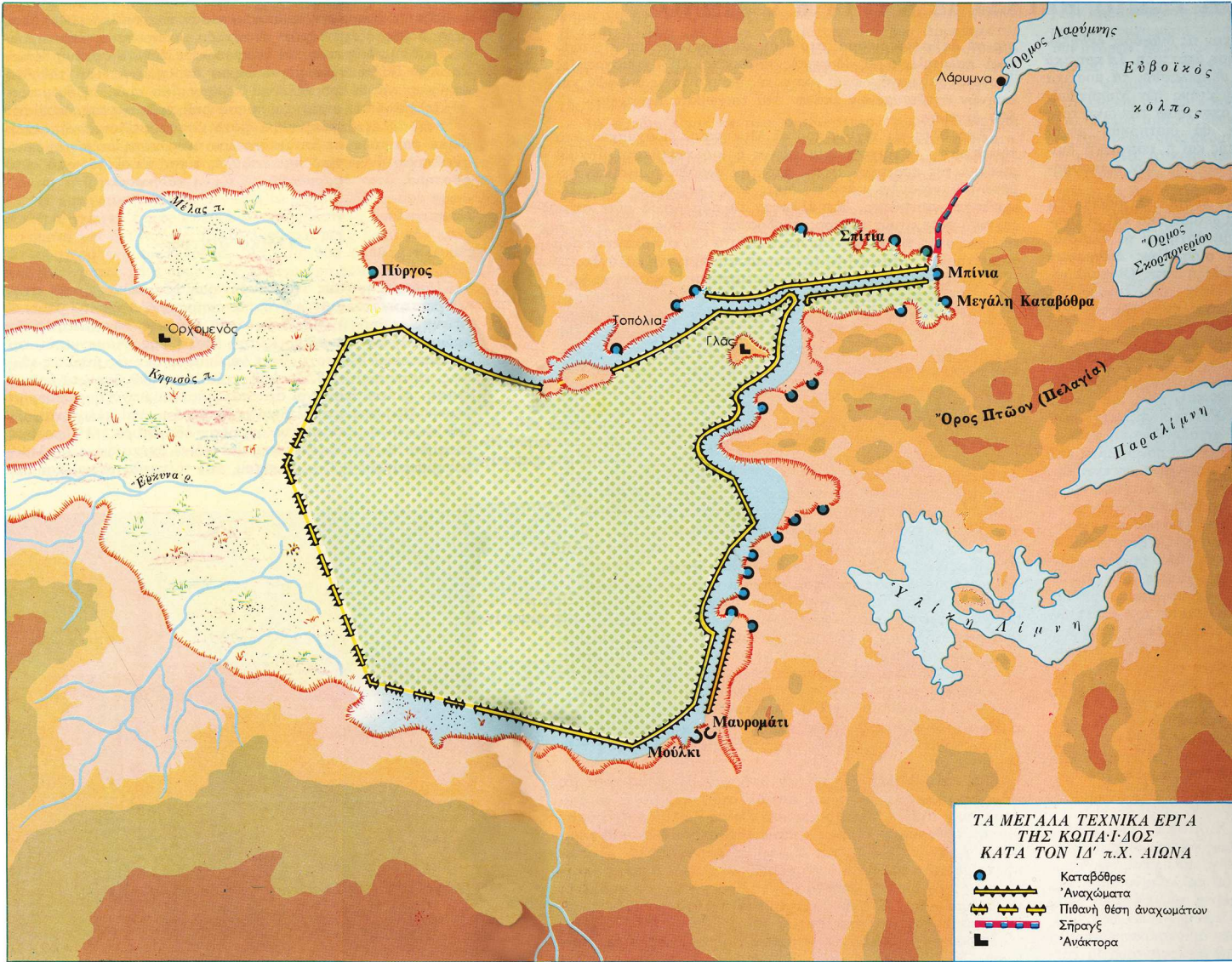





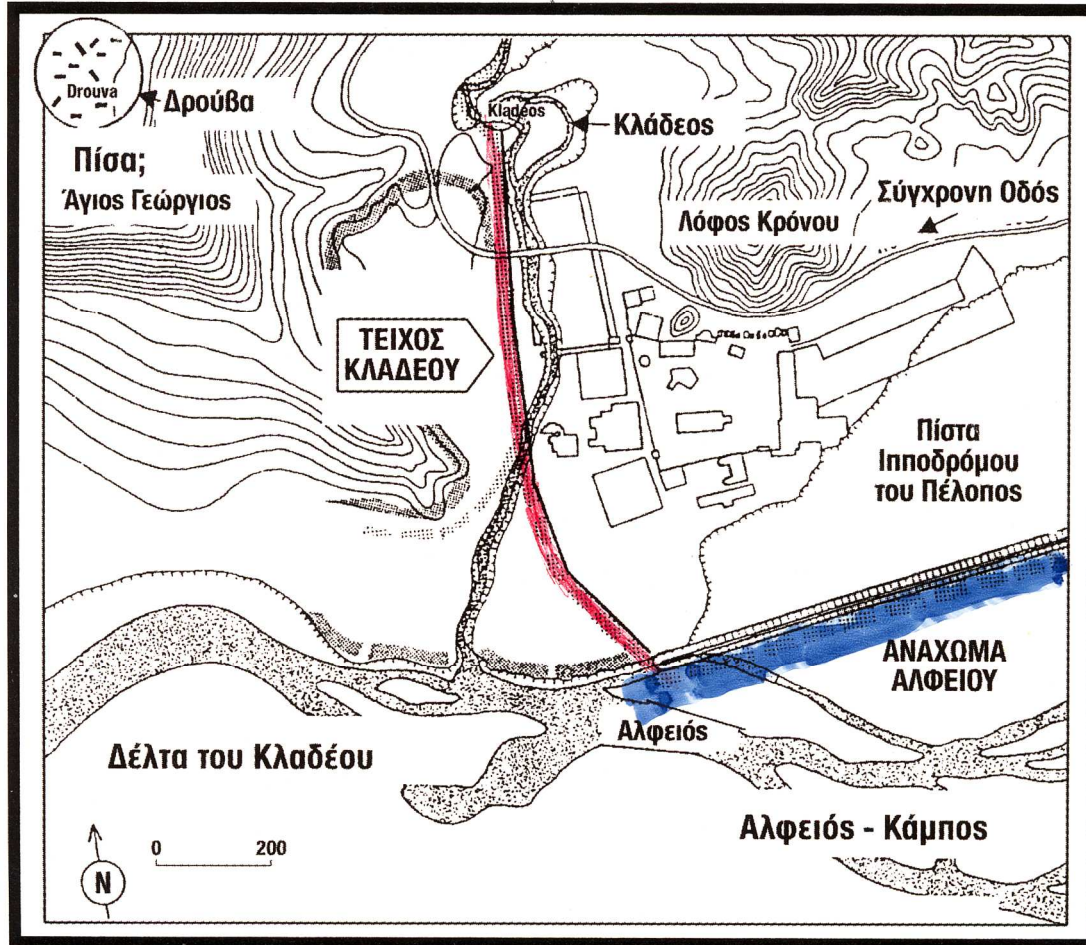

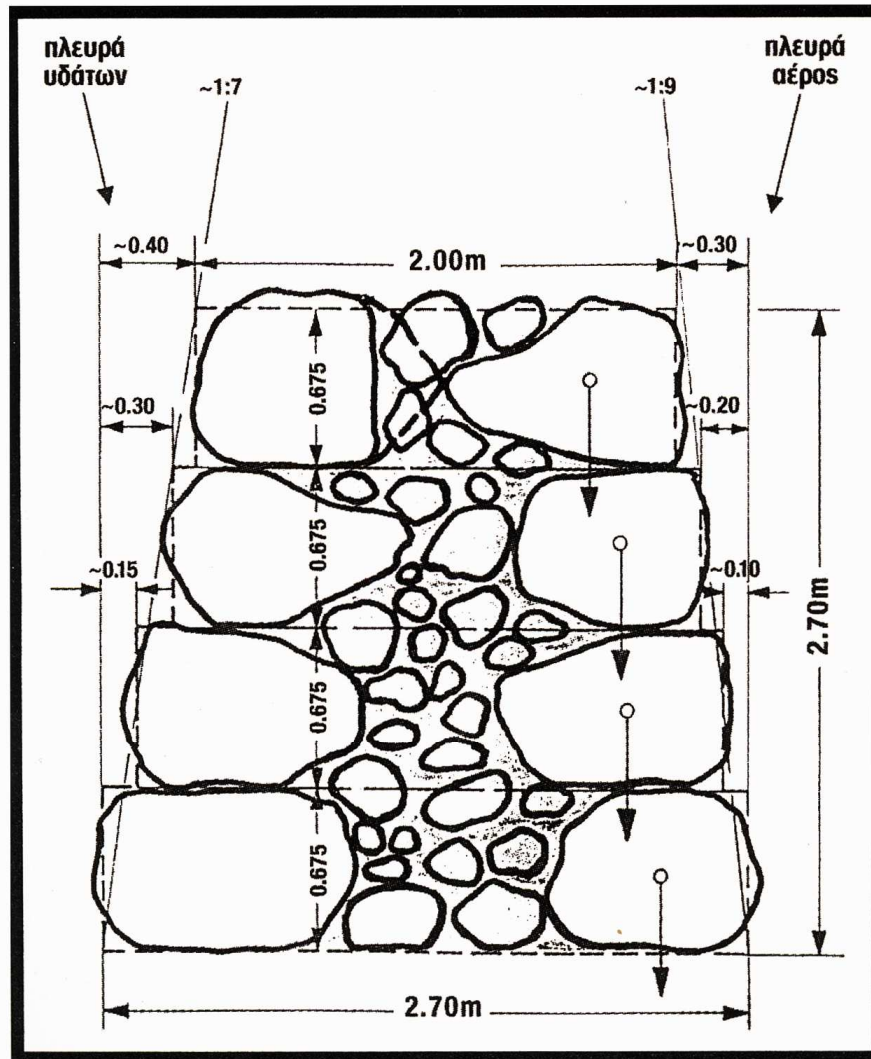



ΘΗΣΑΥΡΟΣ ΑΤΡΕΩΣ

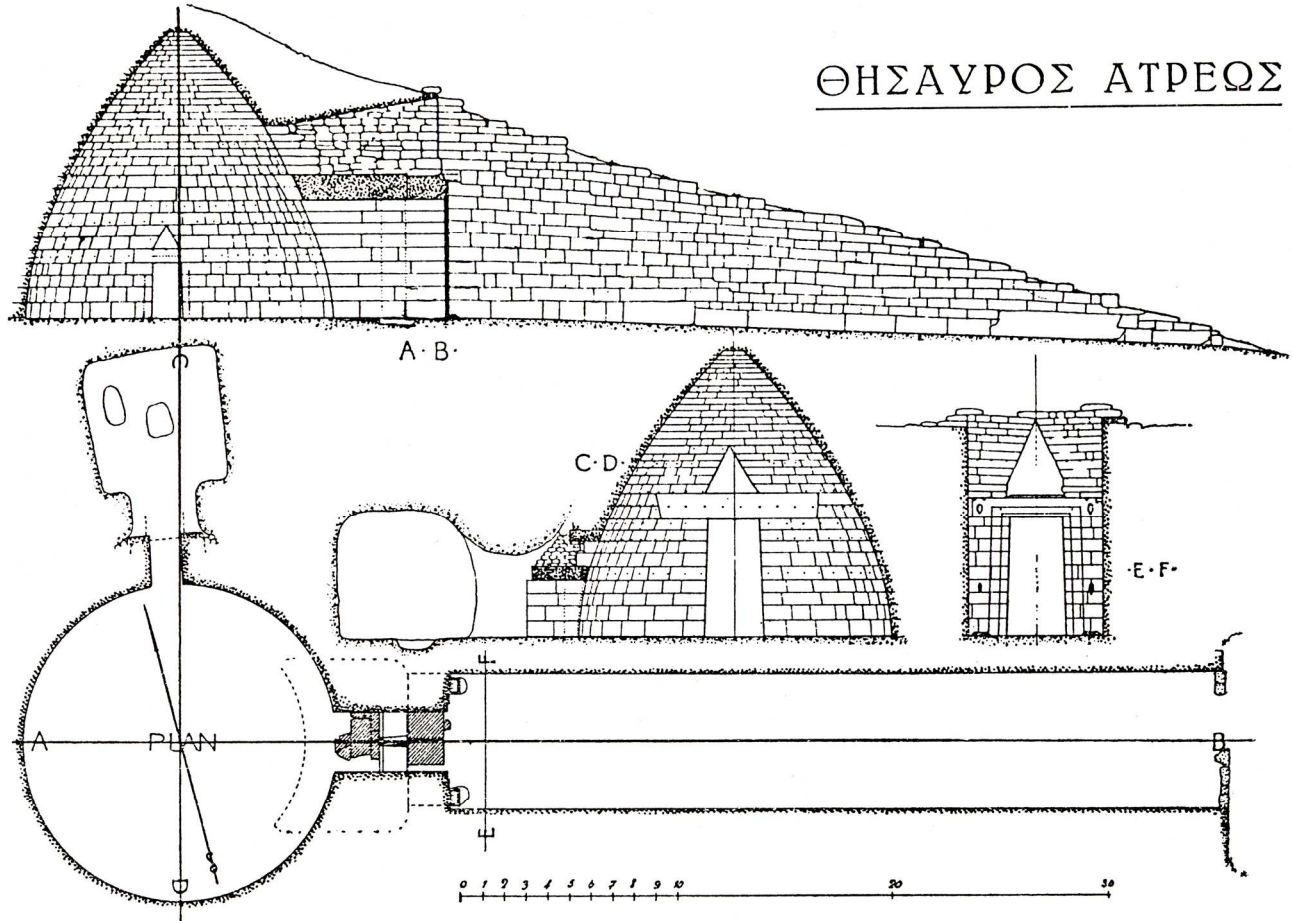

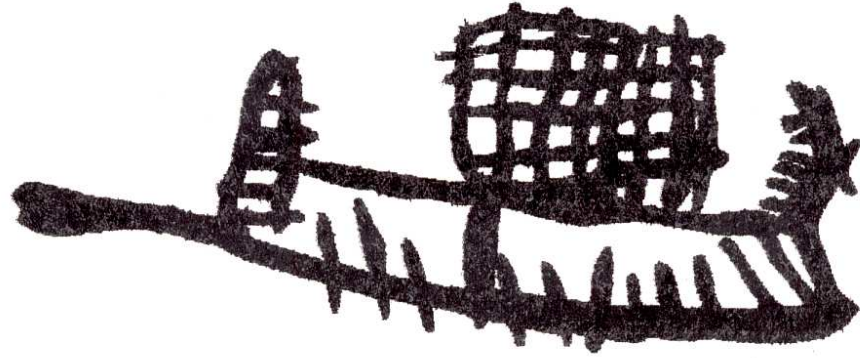

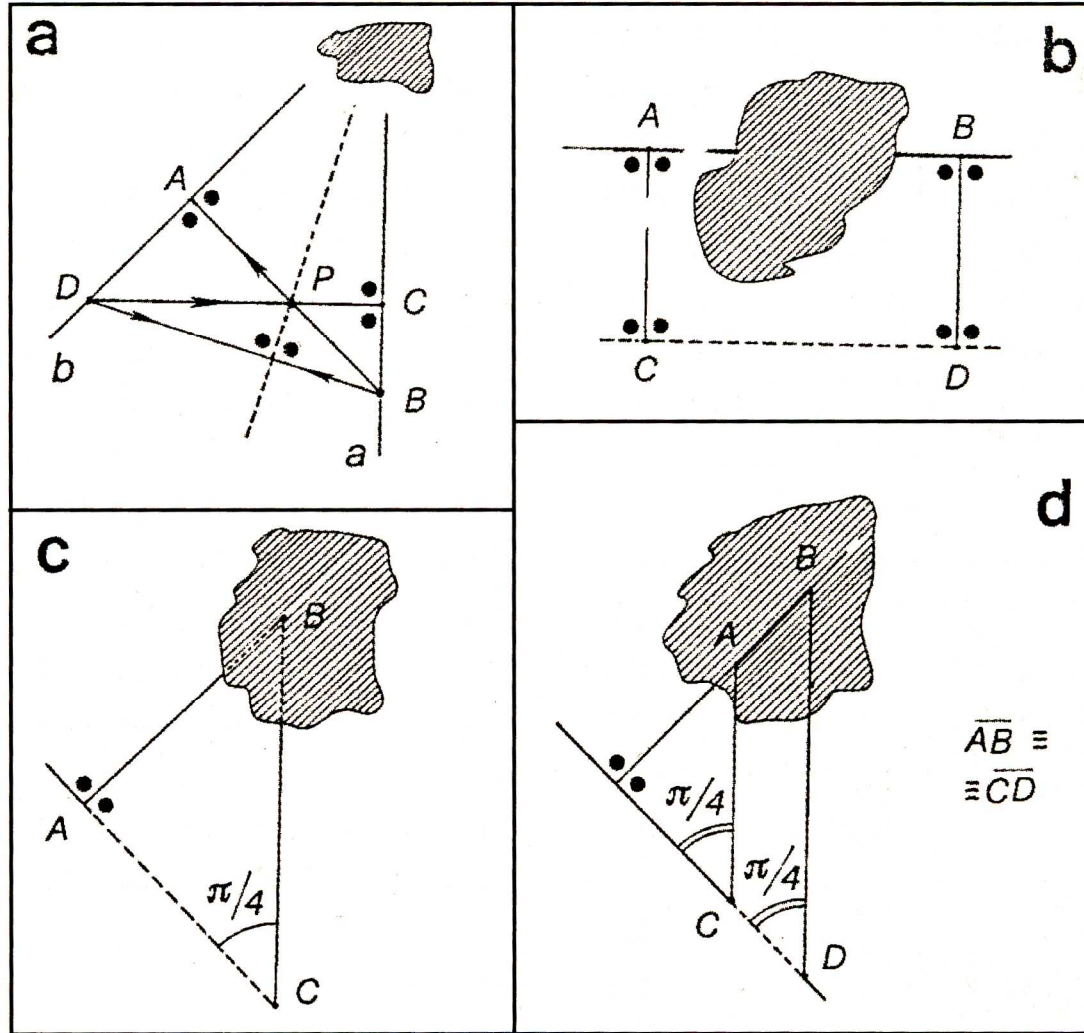



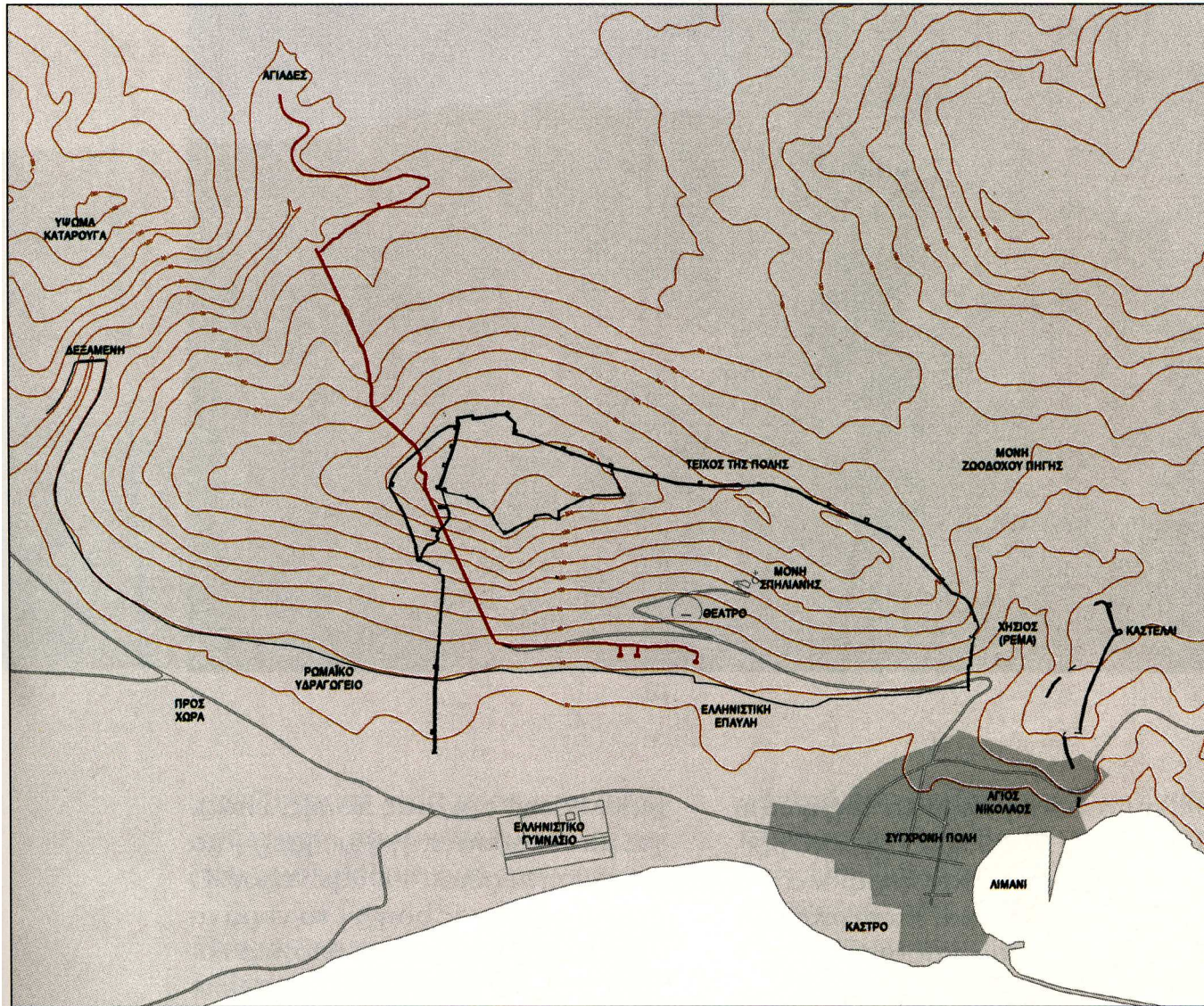

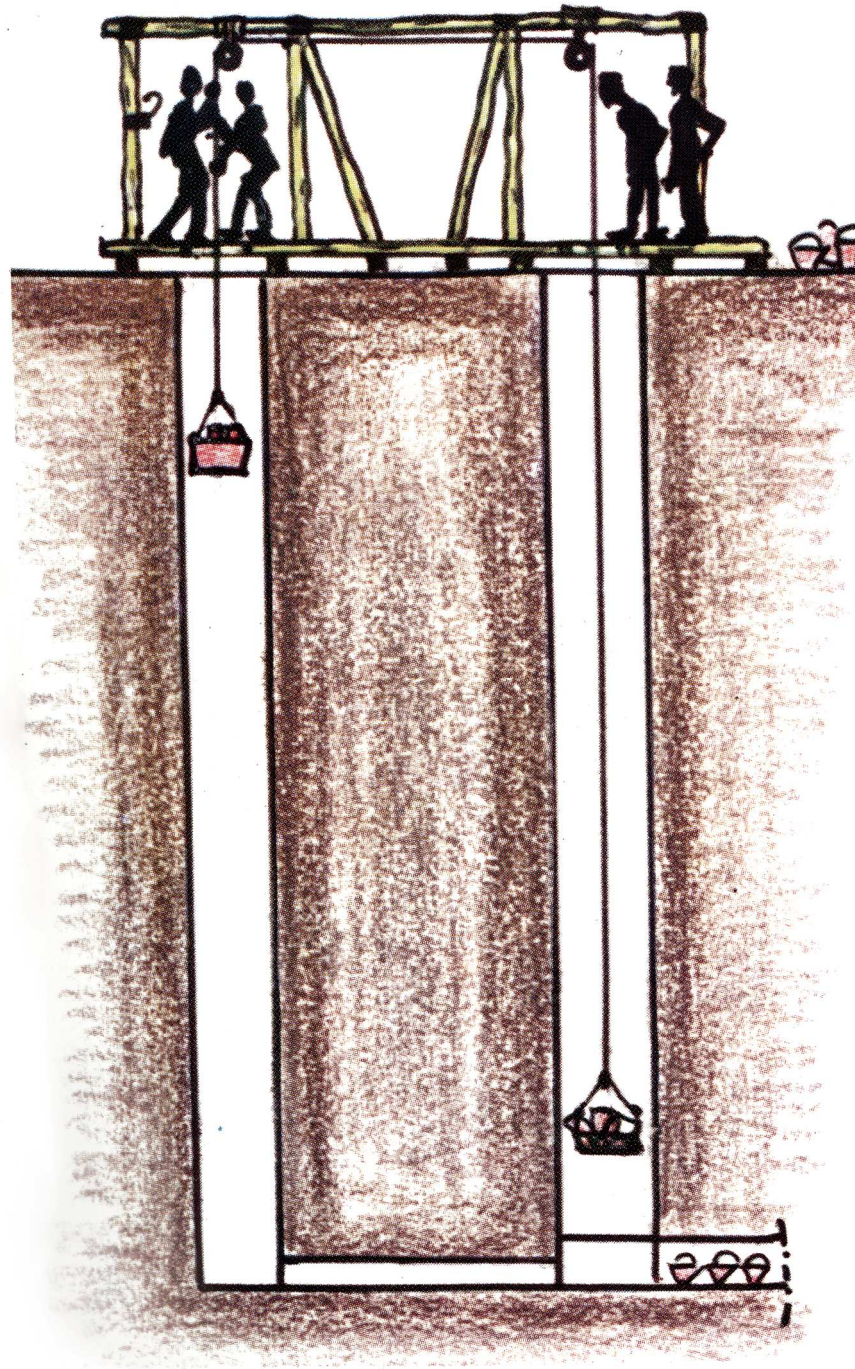





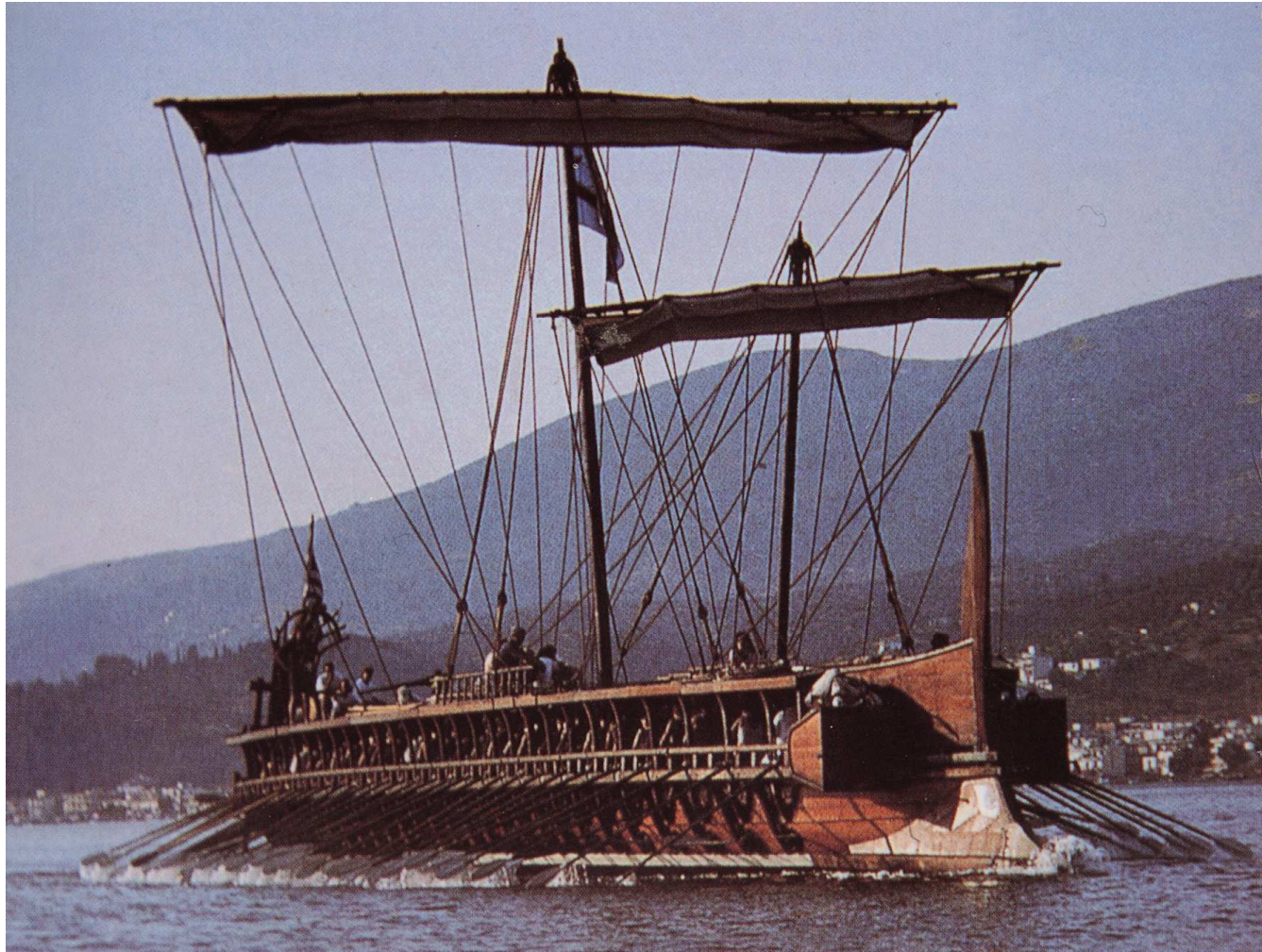

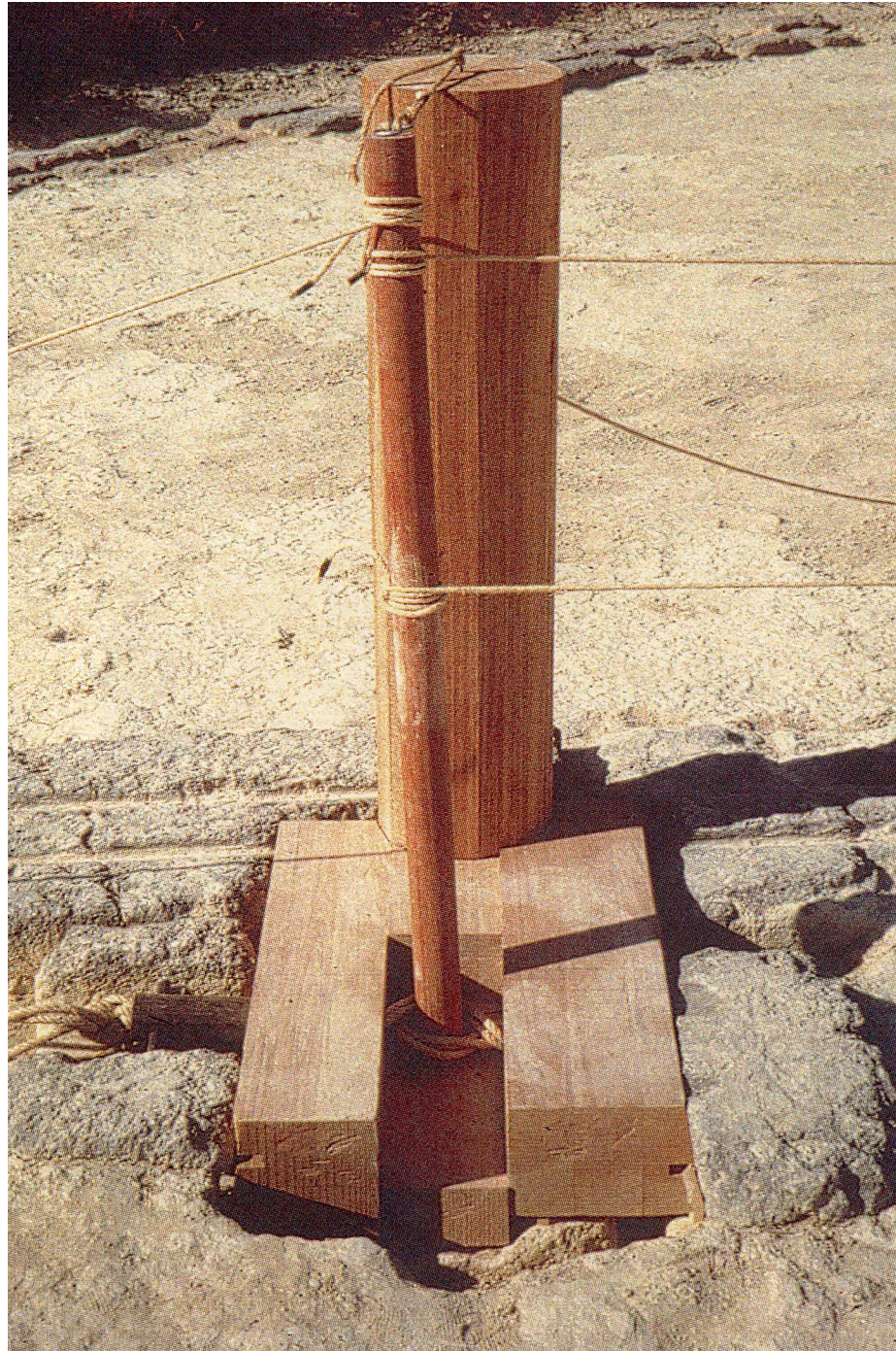

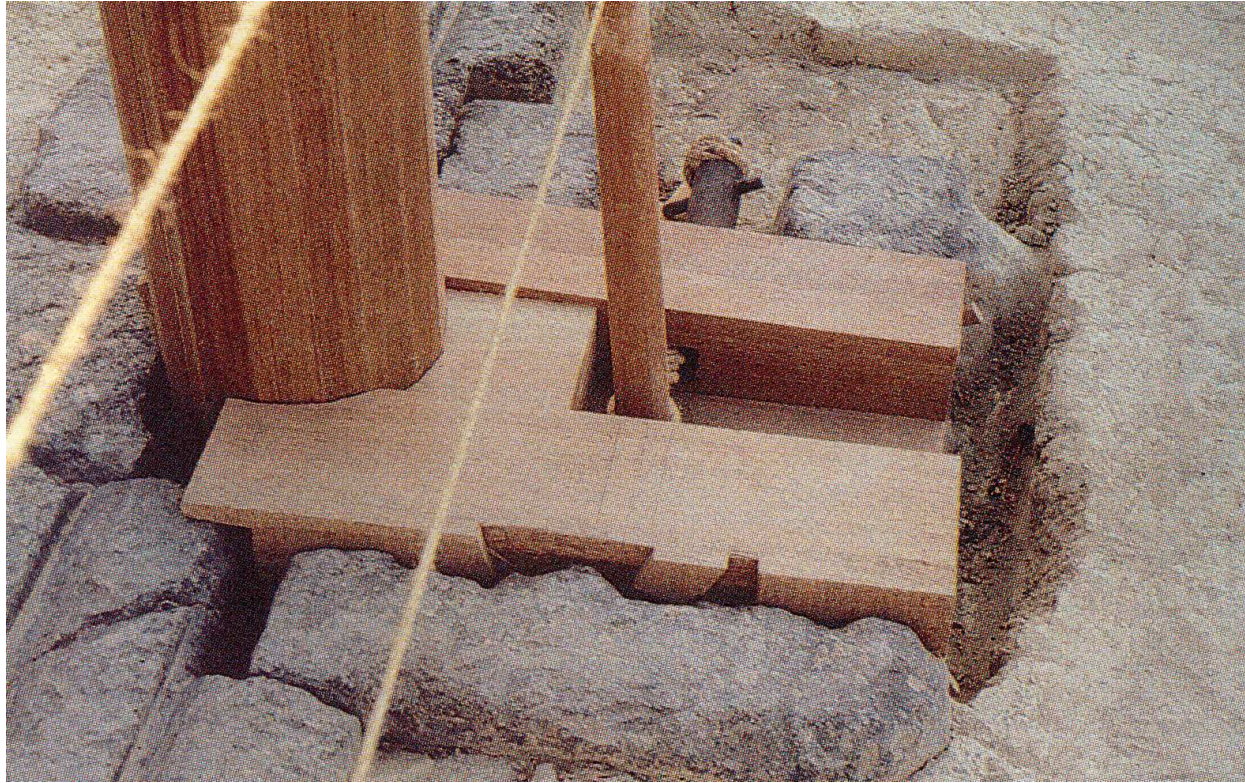

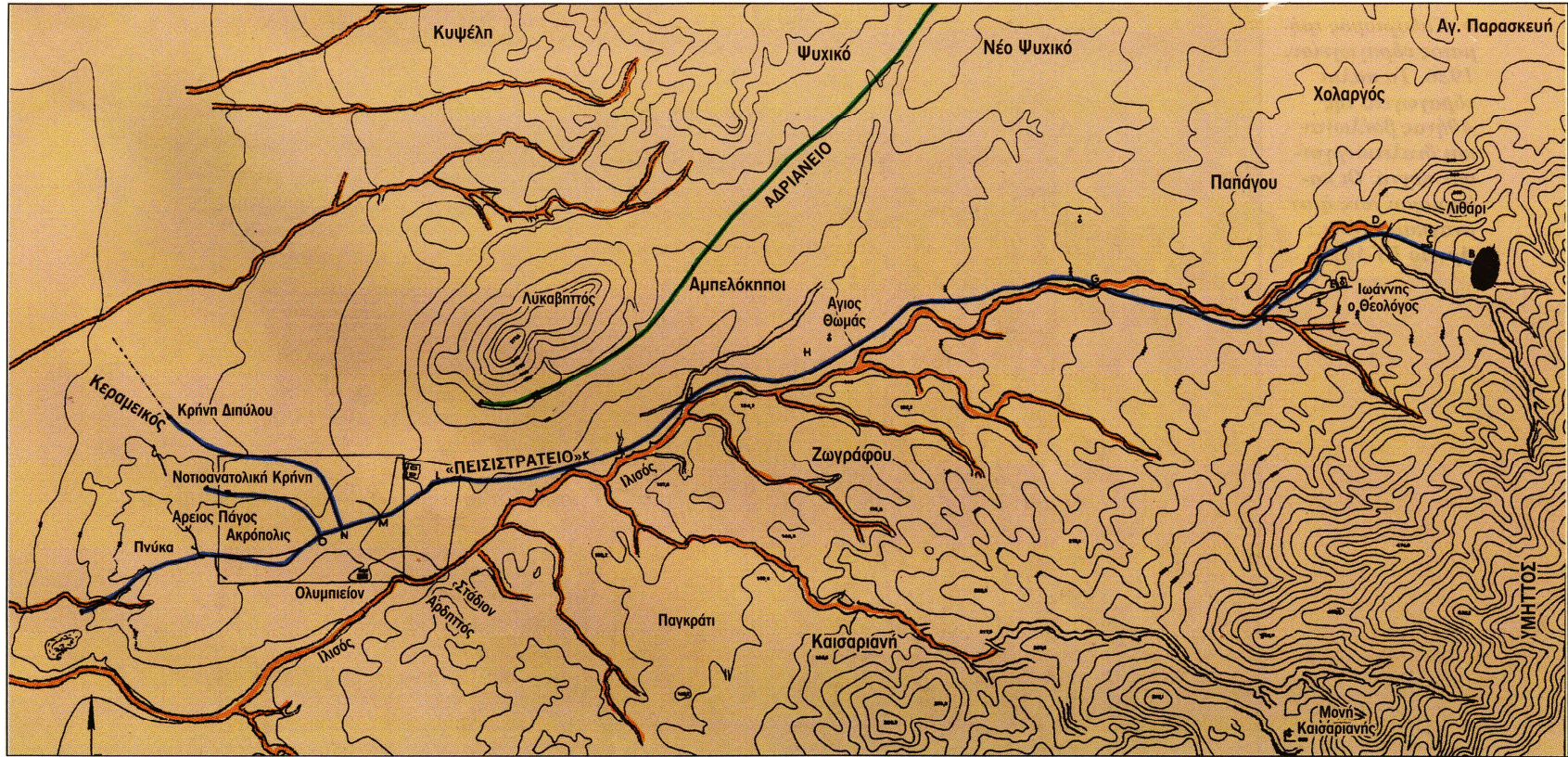

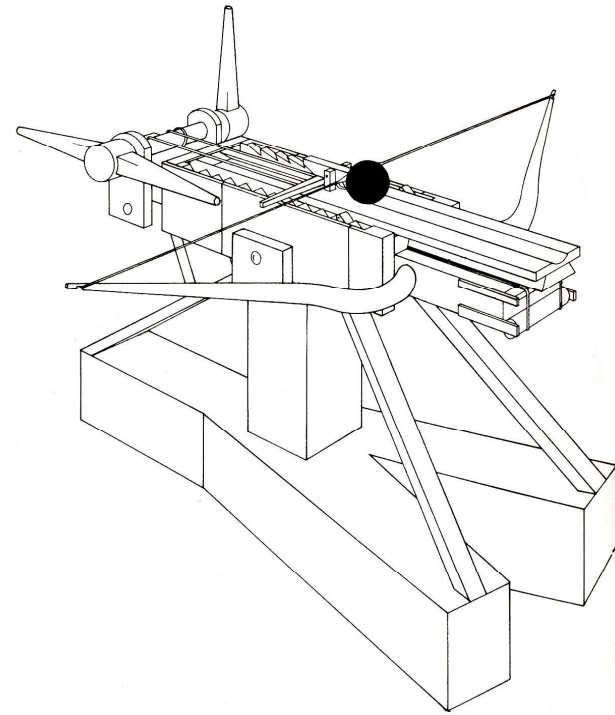
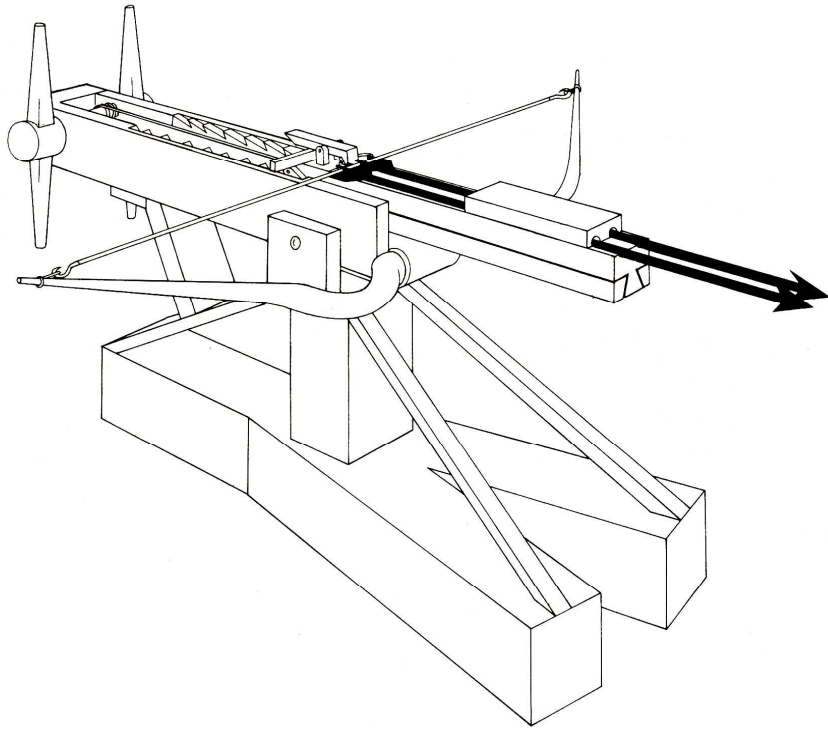

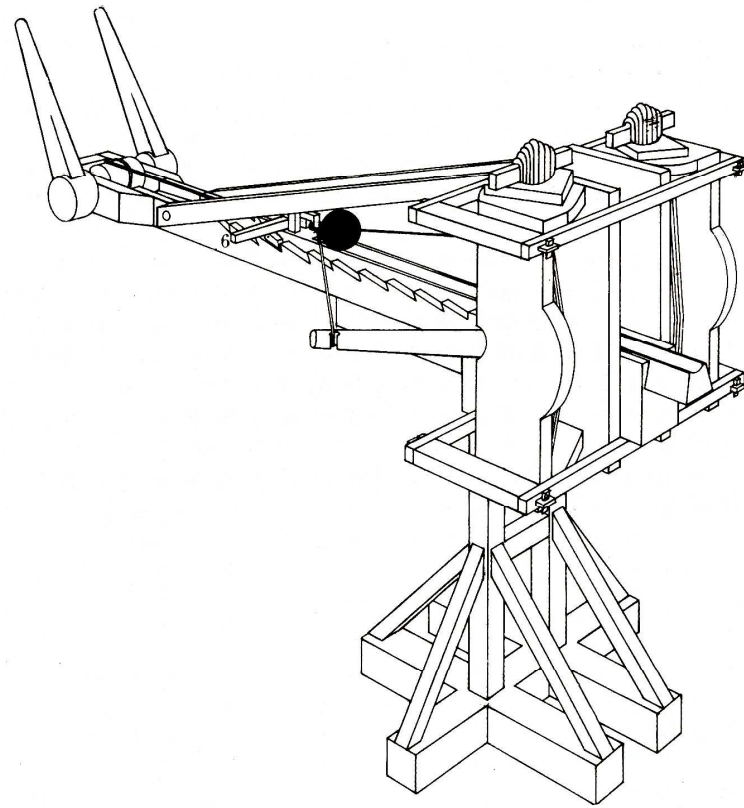
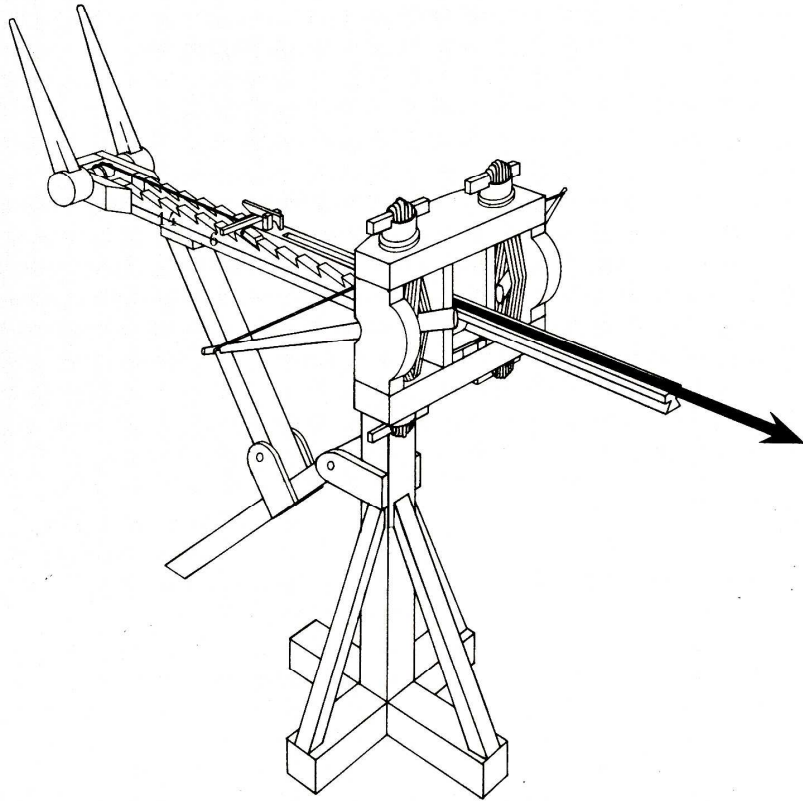

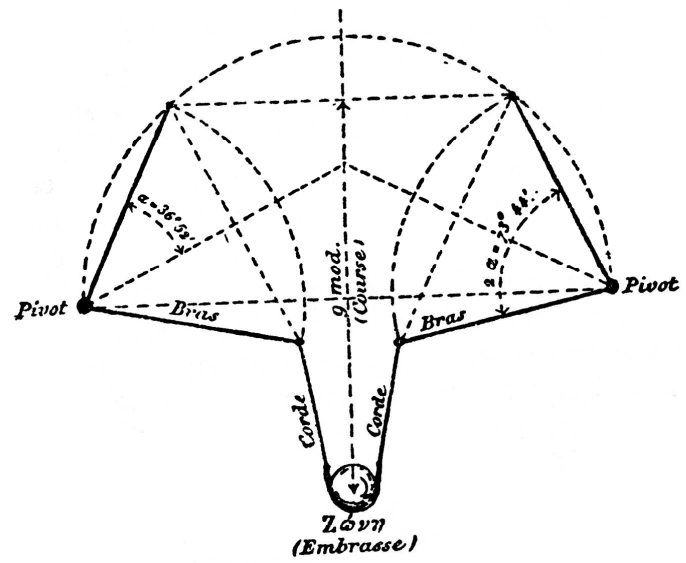
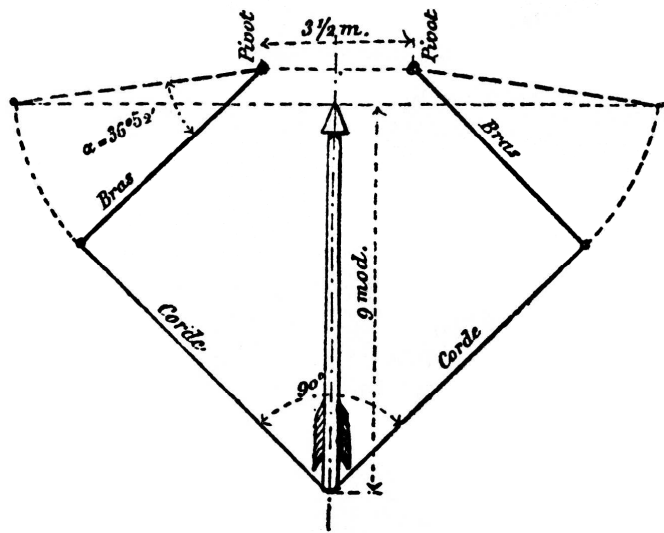





Planche LXV. Fig. I.



J. B. de la Haye sculp.



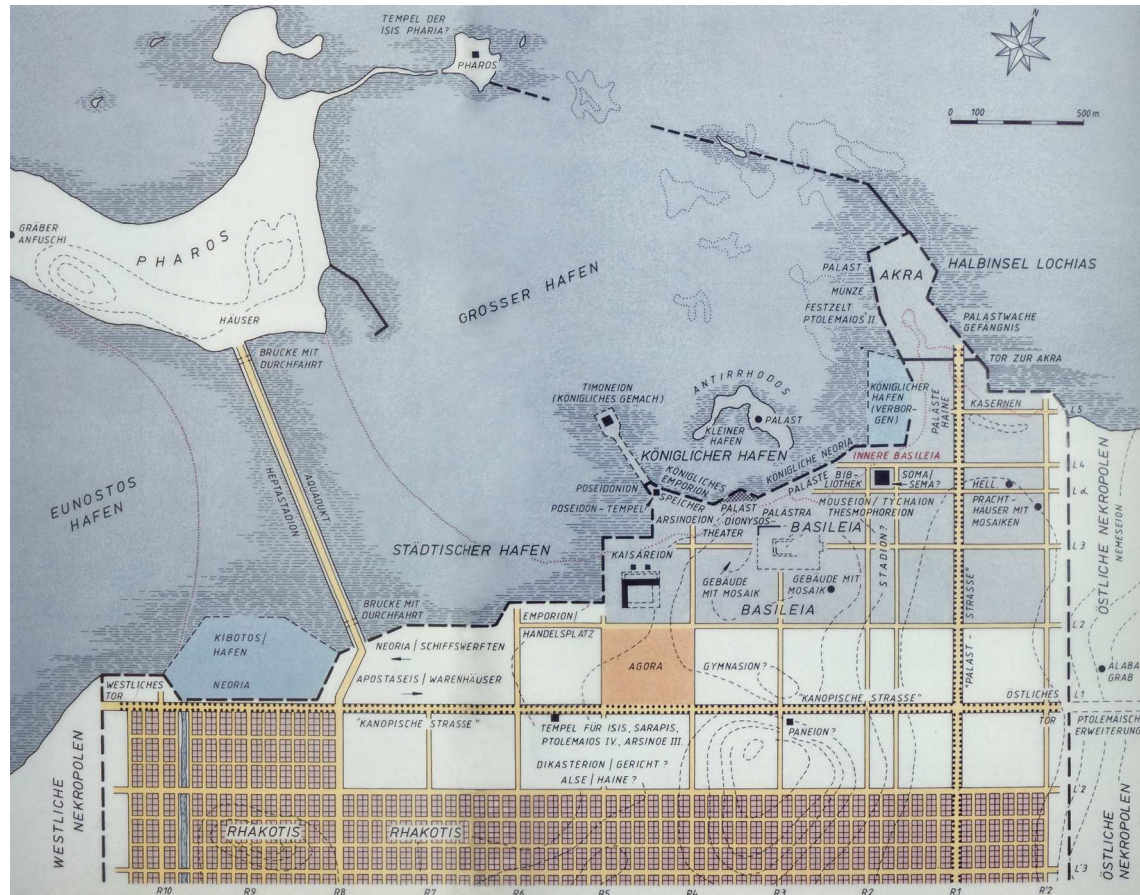
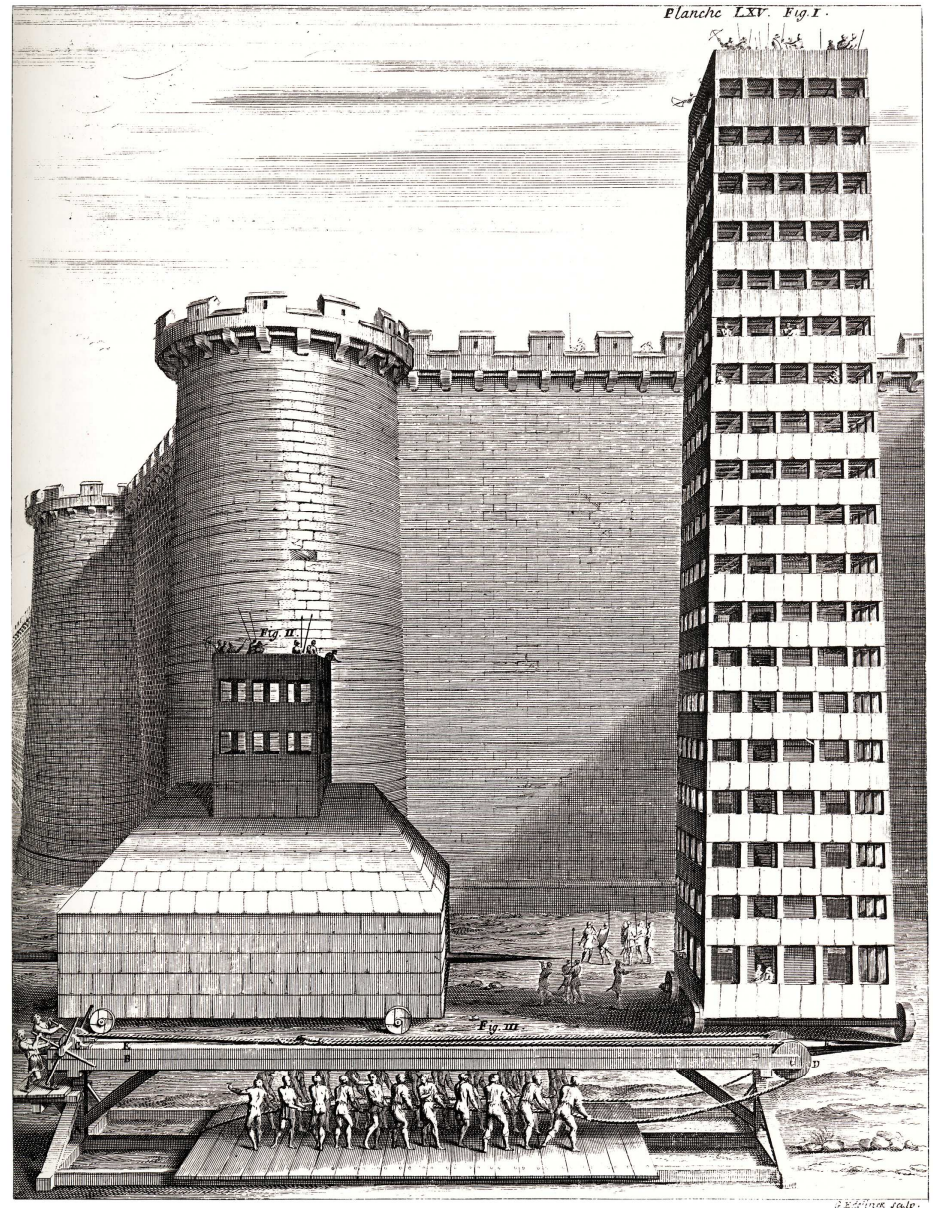
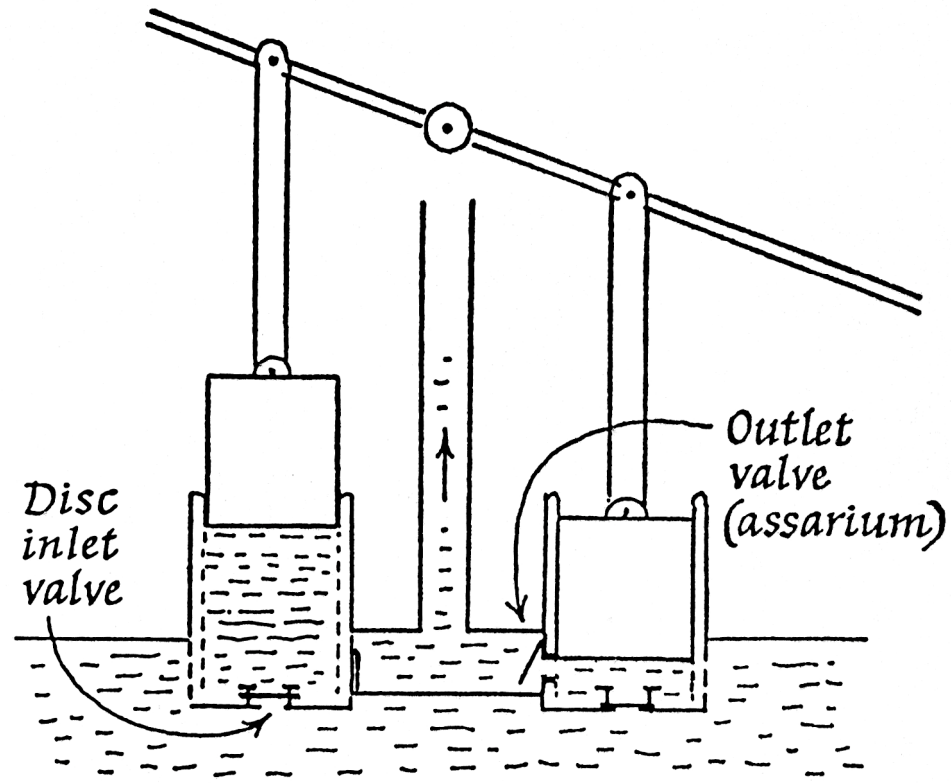
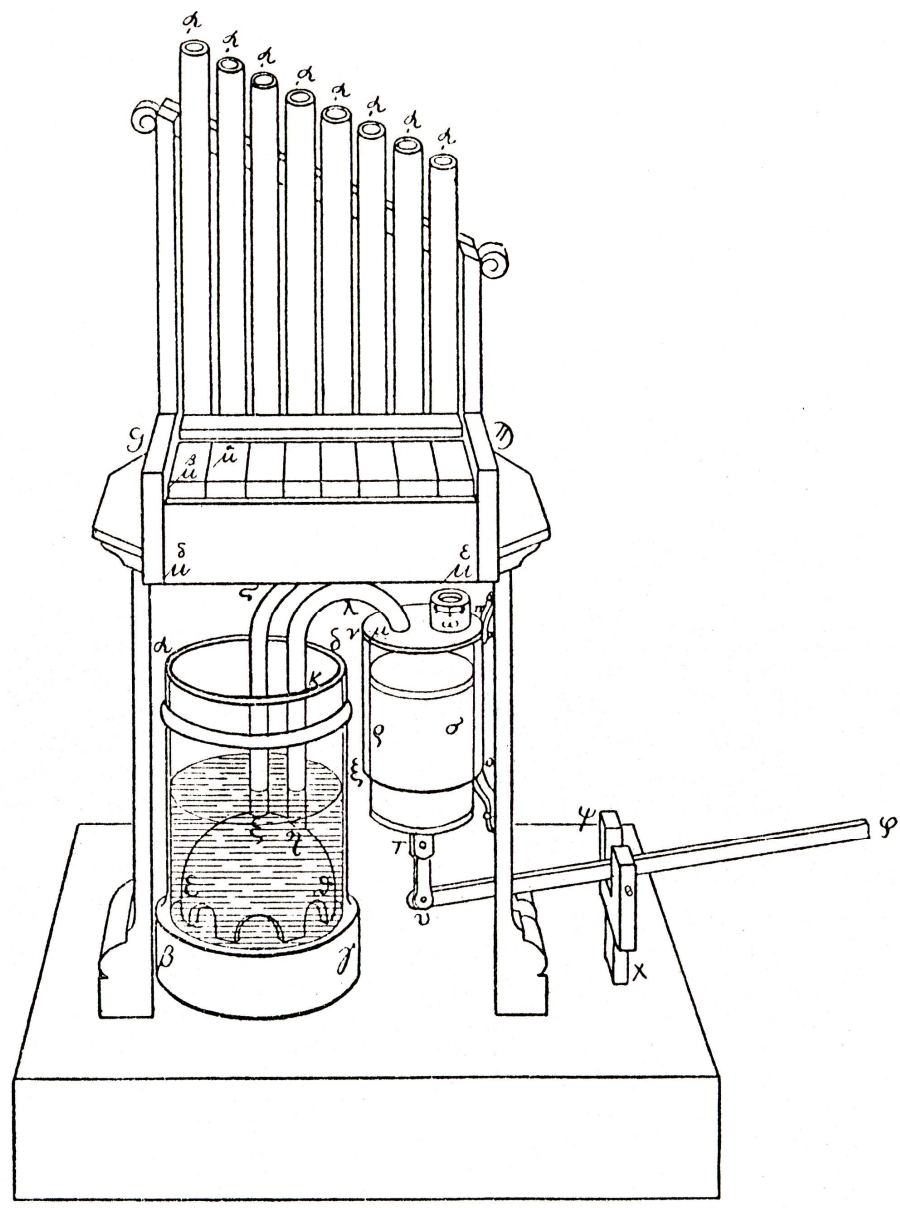

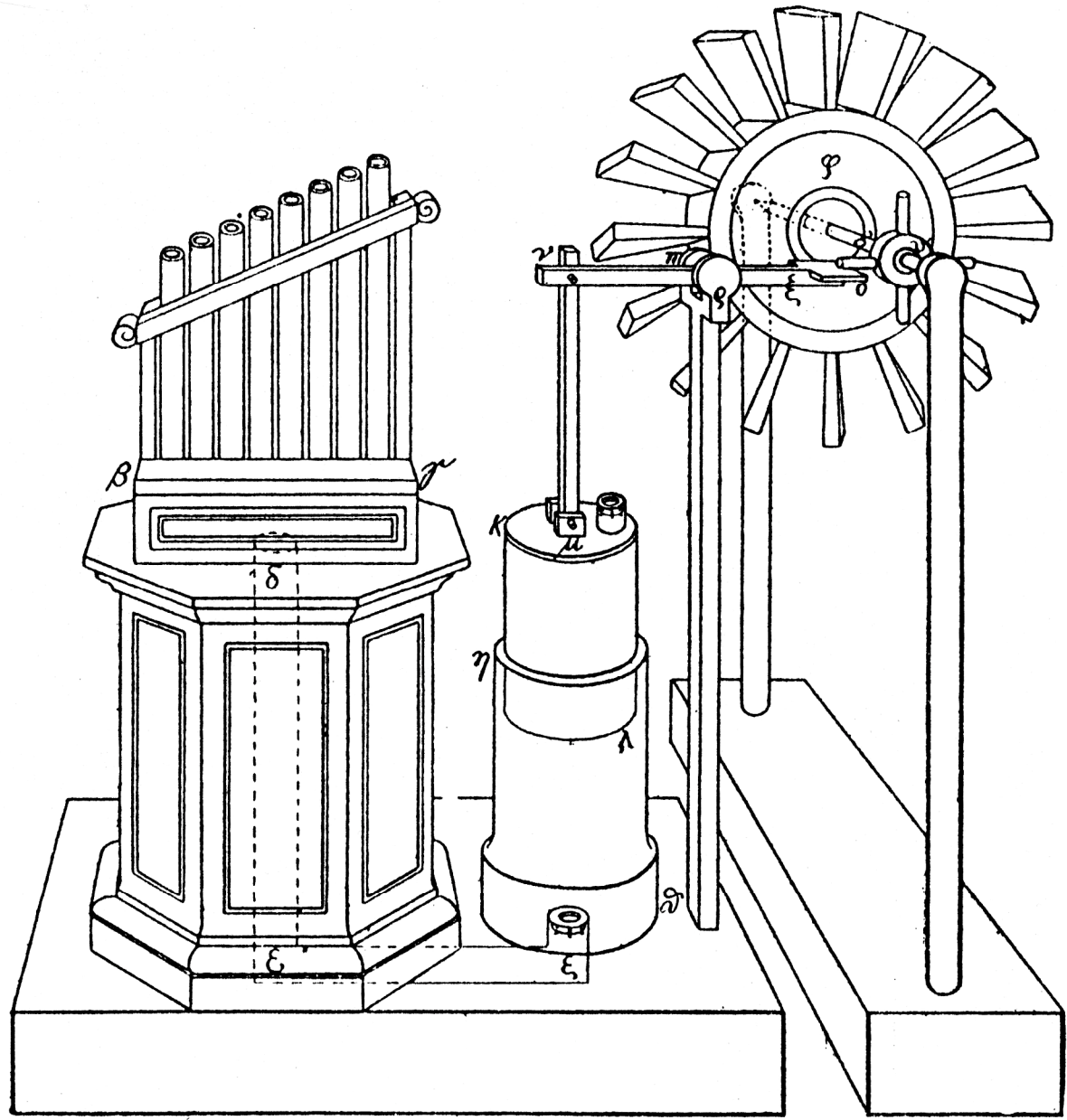



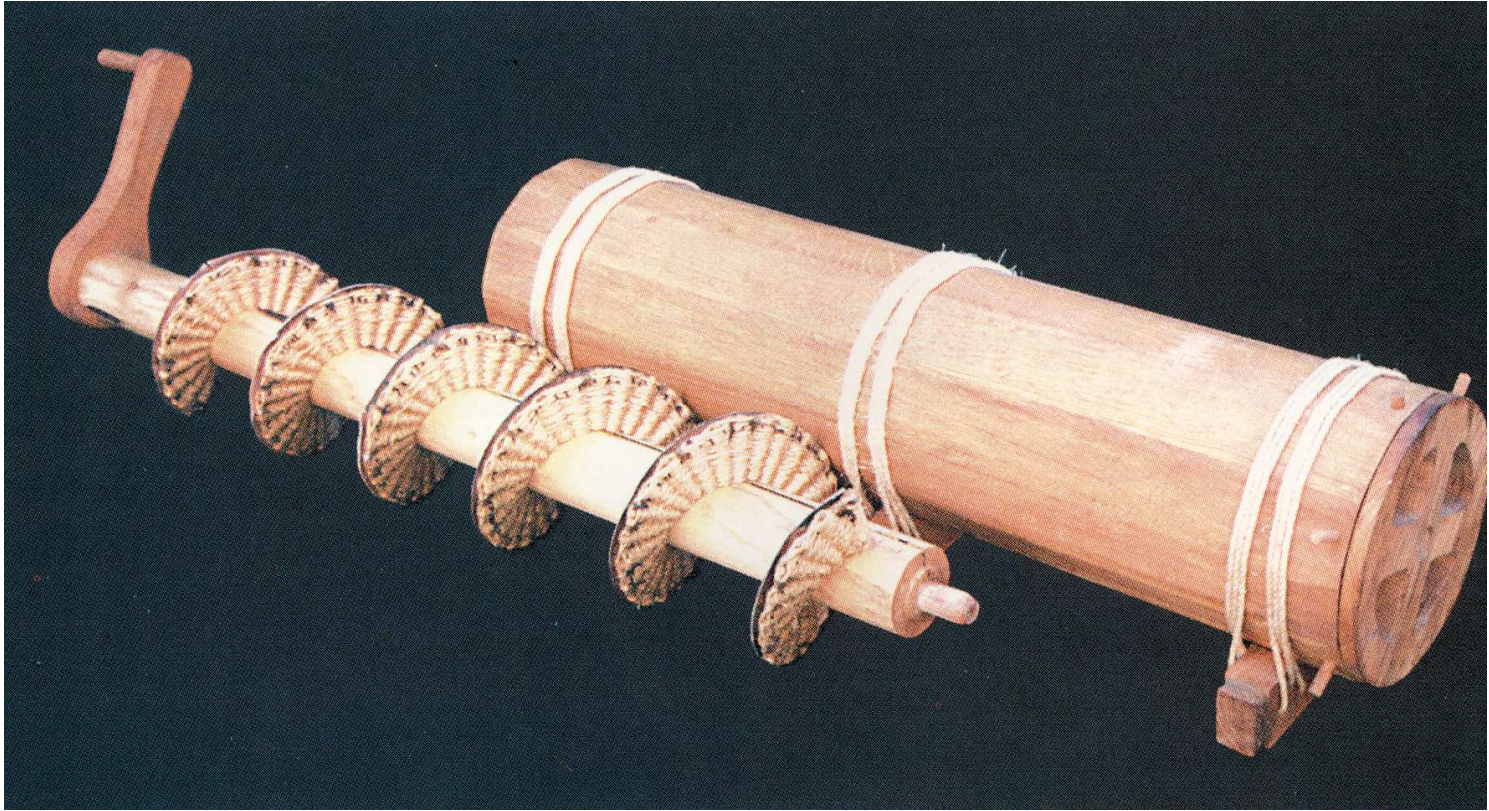

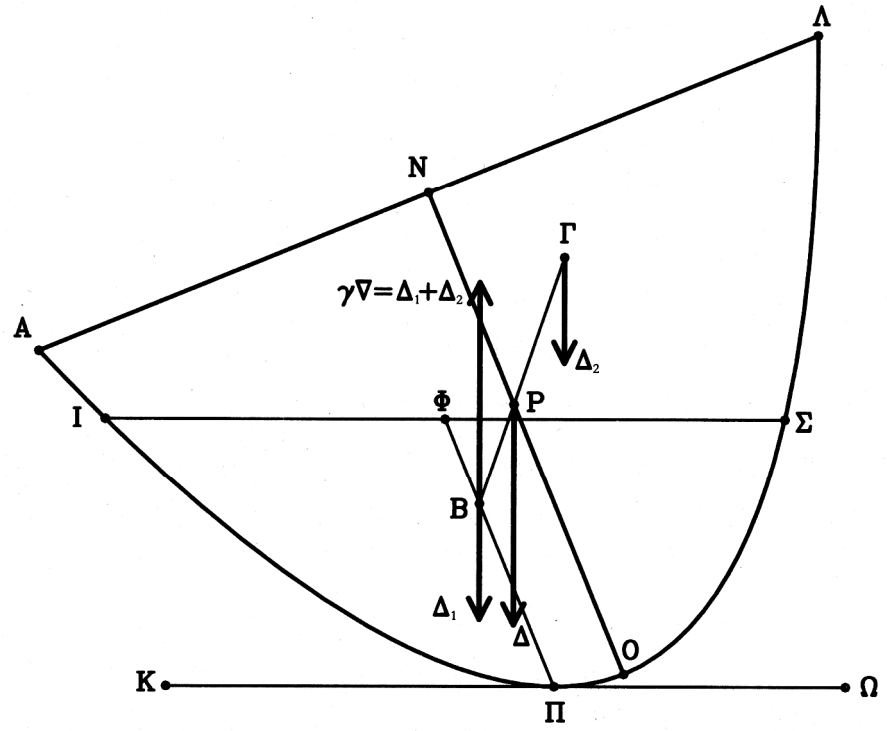

سنة والانبوب الصغير
 الحرقنة التي تخرج منه
 وصورة الخار الذي
 الانبوب الصغير الذي
 وصورة الخار الذي
 وصورة الخار الذي
 ما خارج النوب في
 طويح الماس في ارضه



صاحب الحرقنة
 التي تخرج منه
 صورة الخار الذي
 الخار الذي
 الماس في ارضه
 في حمار وصفت
 الاواني التي
 الماس في ارضه
 الوصف في حمار
 لعم السليمانية
 التي تخرج منه
 التي تخرج منه
 التي تخرج منه
 التي تخرج منه



الساكنات
 في حال ايمان وكونه في ساكنات الماس في ارضه
 كل ايمان وكونه في ساكنات الماس في ارضه
 ساكنة في ارضه في ساكنات الماس في ارضه
 الحرقنة في حمار وصفت
 فانها اذا كانت في حمار وصفت
 في حمار وصفت
 في حمار وصفت









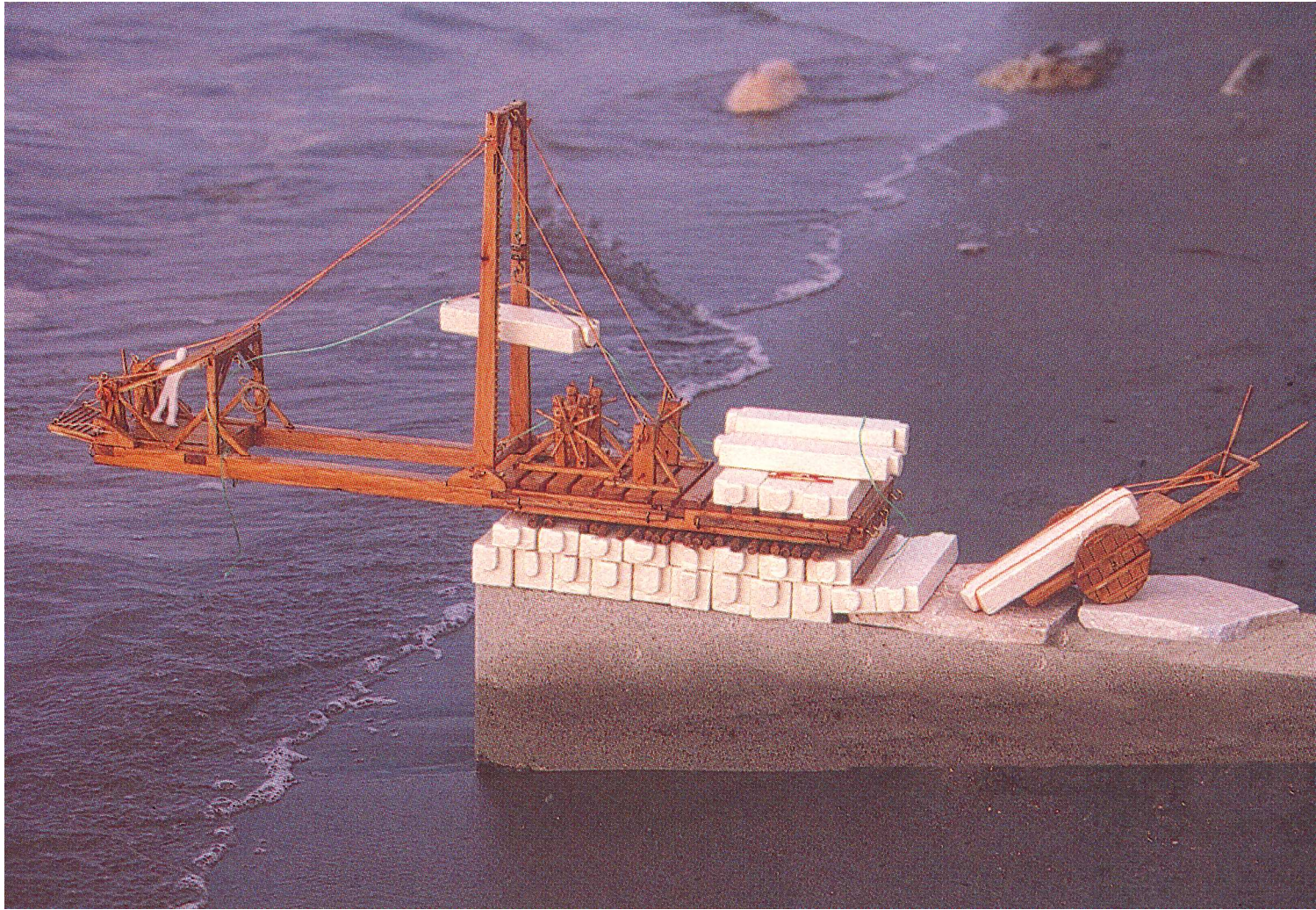

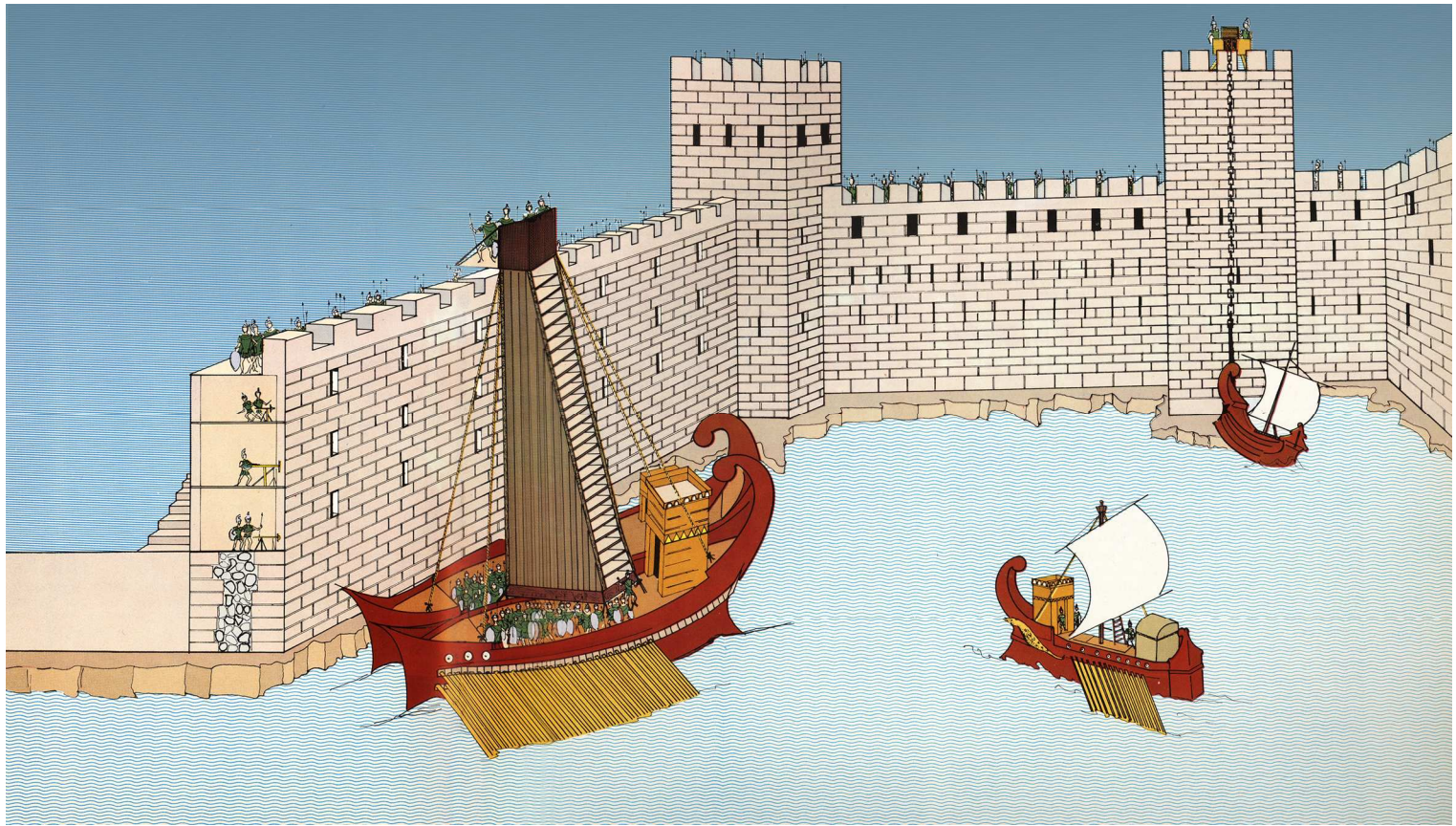

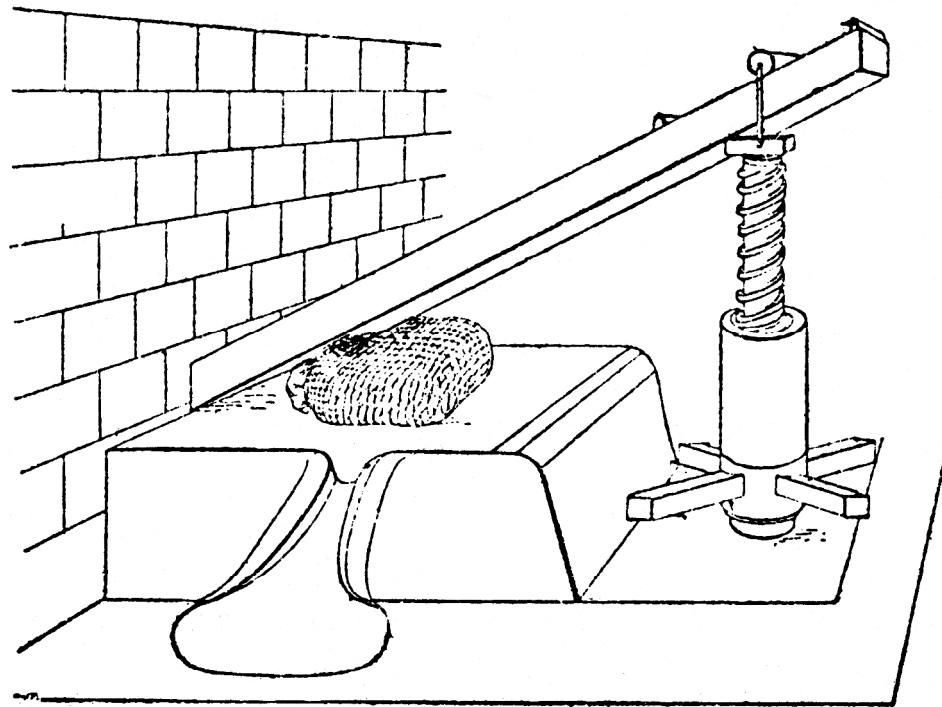



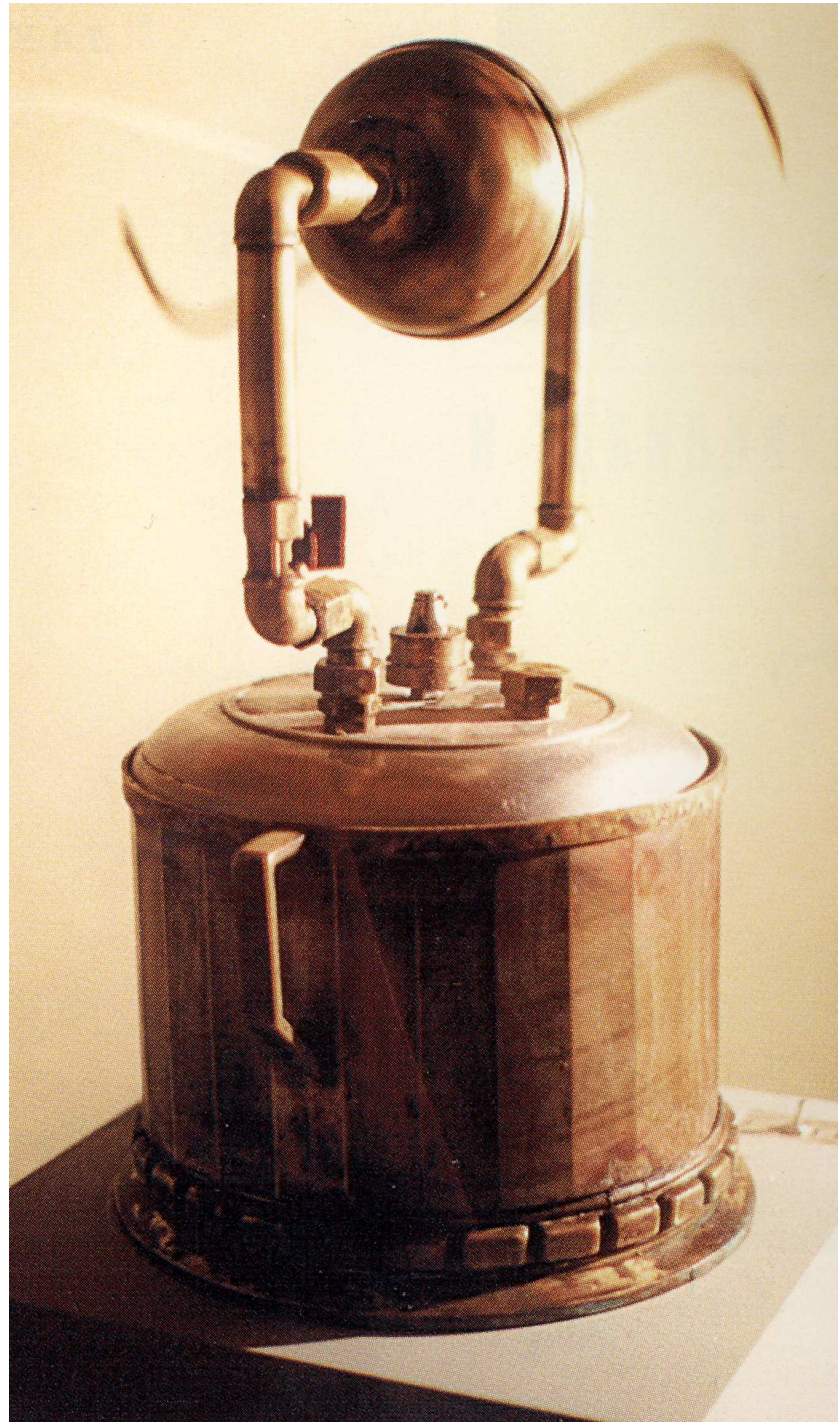

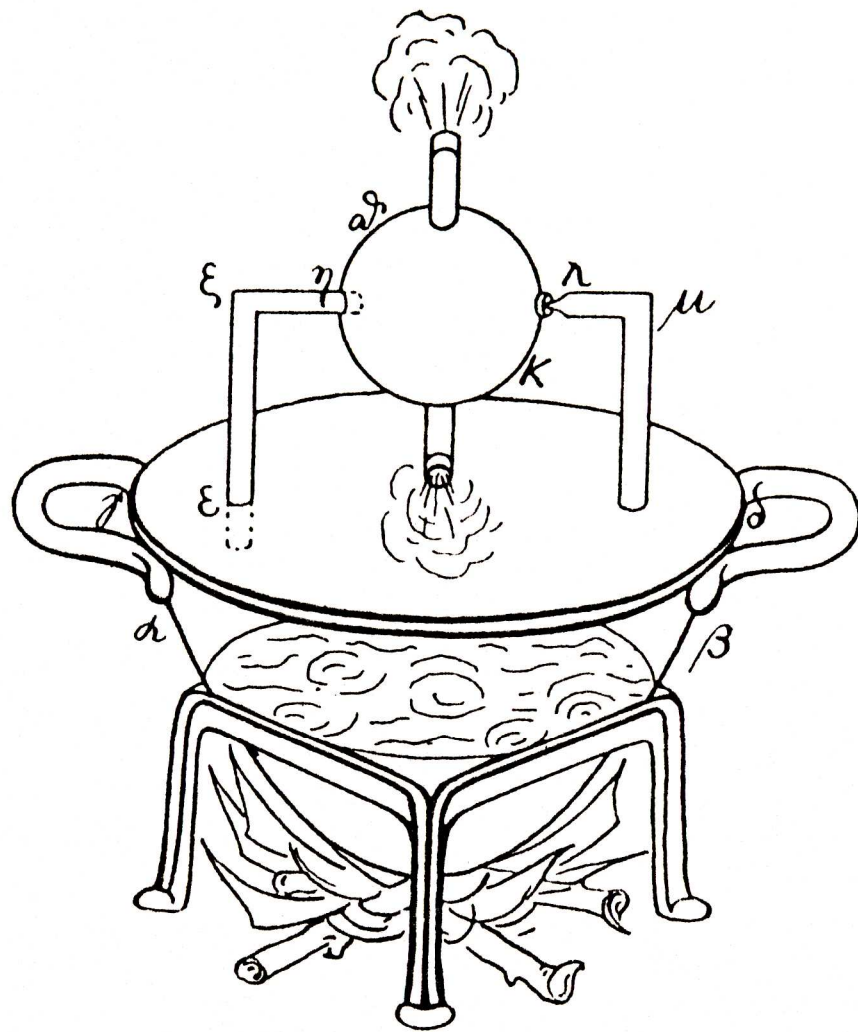

5

10

15

20

