

Research and innovation in Health and Societal Challenges : A perspective from Greece

Nicos Maglaveras

Professor & Director - Lab of Medical Informatics
& Computing

Dept. of Medicine - Aristotle University

Lab of Informatics for big bio-data

CERTH – Institute of Applied Biosciences

Thessaloniki, GREECE

EMAIL : nicmag@med.auth.gr

Some background.....

- Health delivery is becoming more preventive, continuous, and personalized
- A large scale of biomedical data and information are becoming available for use in health delivery
- Biomedical data are produced by diverse sources and technologies
- Medical decision support is directly related with data quality, medical evidence and intelligent semantics extraction and integration

Main Features of Personal Health Systems (PHS)

- Personal health systems aim in the monitoring, intelligent interaction between physicians and patients, implementation of multiparametric information analysis, providing coaching and intervention possibilities, enable medical decision support, and personalize health services delivery.
- The main layers as it concerns information a PHS are the **data** layer, the **information** layer, the **knowledge engineering** layer and the **output** of information processing and analysis.
- In all the above mentioned layers, the primary concern is the **quality both in data and information**, thus increasing the need for filtering out noise and artifacts from wherever they originate.
- PHS lead to new R&D pathways as it concerns biomedical information processing and management, as well as new pathways in designing **new intelligent medical CDSS** enabling timely **medical interventions** and **quality** health care delivery.

PHS – TELEHEALTH - AAL

- Telehealth is expected to become a reality in the near future
- Today we are developing the third generation of telemedicine systems, implementing **closed loop approaches** such as e.g. in the HEARTCYCLE project
- Use of the above mentioned systems / modules is expected to be used in the **multimorbid patients management** arena and the **AAL and healthy ageing** arena, involving users more and more
- In the end PHS, PGS, VPH, access platforms, are expected to be **integrated** and work in an **interoperable** and **reconfigurable** way for providing **health services**

Major challenges in PHS data & information gathering

- Building large scale databases at multi-level biological, anatomical, physiological representations of the human organism in laboratory, clinical and daily life
- Embedding intelligence and medical knowledge in personal health systems
- Multi-parametric modeling for clinical decision support
- Contextualization of healthcare services
- Interoperability across personal health systems and the clinical IT infrastructure (EHR, PHR, PGS)
- Patient and healthcare professionals' acceptance and education
- Evaluation aspects of coordinated care (CC) and connected health (CH)

The “Big Data” Scene

- Data:
 - are generated in huge volumes, fast & continuously
 - vary in nature and complexity
 - vary in structure; it can be even unpredictable! (=> ad-hoc solutions required)
- “Big data” characteristics: **Volume, Velocity Versatility Veracity (4V)**
- “Big data” management:
 - **Cloud-based** approaches have been proposed
 - But still:
 - efficient distribution of data and workload to support **massive parallel processing** is a challenge
 - **data-intensive processing** over a distributed network of computer machines is required

The “Big Data” Challenge

- To generate “**Value**” out data, i.e. mastering the process to derive insight from the data; requires:
 - capturing data, aligning data from different sources, transforming data for analytical processing, modelling data and, finally, understanding the output as well as visualizing and sharing the results
- Beyond “big data” management:
 - **Scalable Data Analytics (SDA)** to empower organizations in **extracting knowledge** from their data and **support decision making**
 - Deployment of **flexible and open platform architectures** for data streaming, federated storage solutions and above all robust and scalable data analytics

“Big Data” & Medical Information Systems: A Joined Perspective

- “Big data” technologies are considered the cornerstone of **“Personalized Medicine”**
- Medical information systems are **“big data” producers**, especially when seen in an integrated fashion:
 - e.g. Electronic Health Record + Personal Health Record + Patient Monitoring System + Genetic Profiling (e.g. *Next Generation Sequencers*)
- **Exploiting value from data** is a key quality procedure for healthcare organizations:
 - May help healthcare professionals in decision making and patient treatment

Data complexity scale evolution

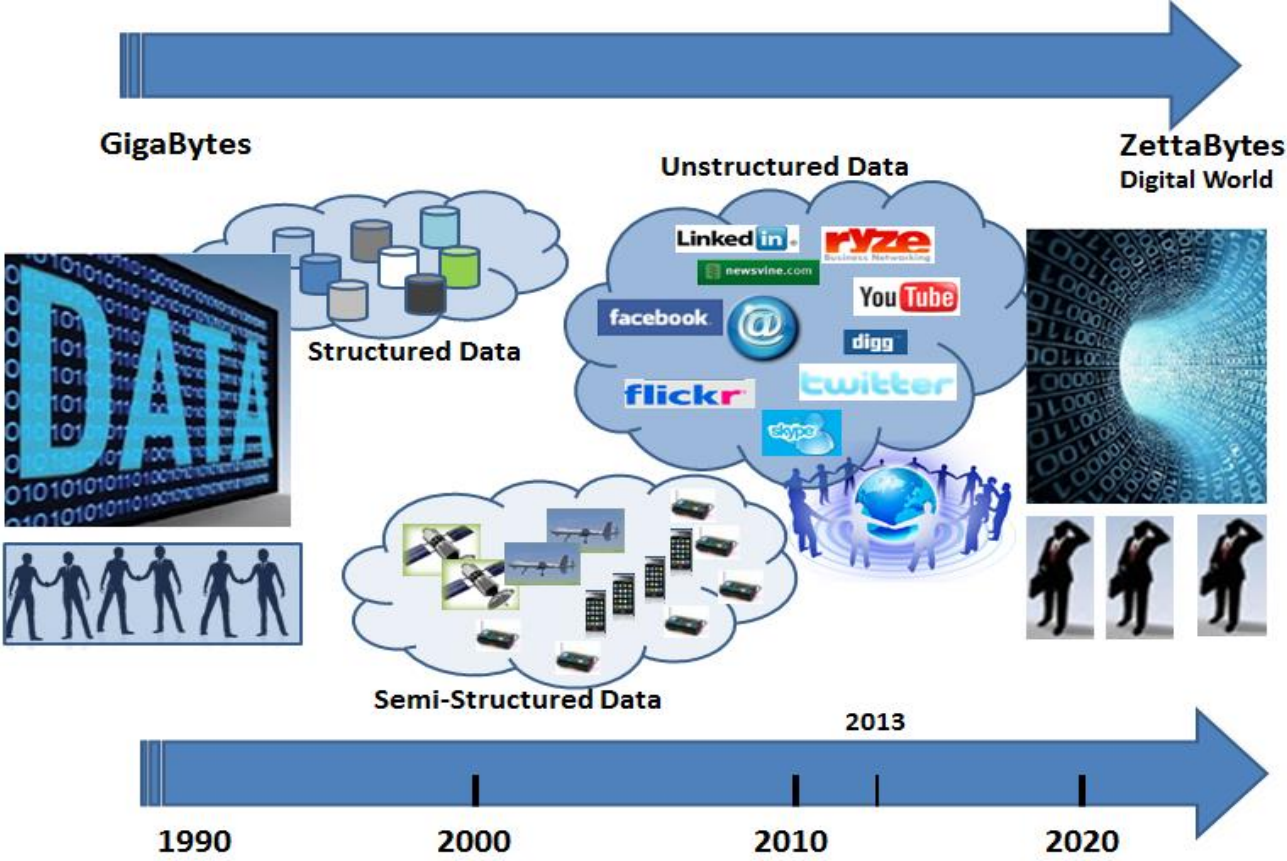

How is the “Big Data” Perspective Contributing in Personal Health Systems?

- Support **wide-scale epidemiological studies** by managing and exploiting the wealth of sensor data
- Support the management and exploitation of data in the context of **wide-scale health-related studies** (e.g. concerning lifestyle) acquired via opportunistic sensing by devices like smartphones
- Contribute in **individualized care** through scalable data analytics

BIG DATA IN HEALTH – THE AEGLE PROJECT

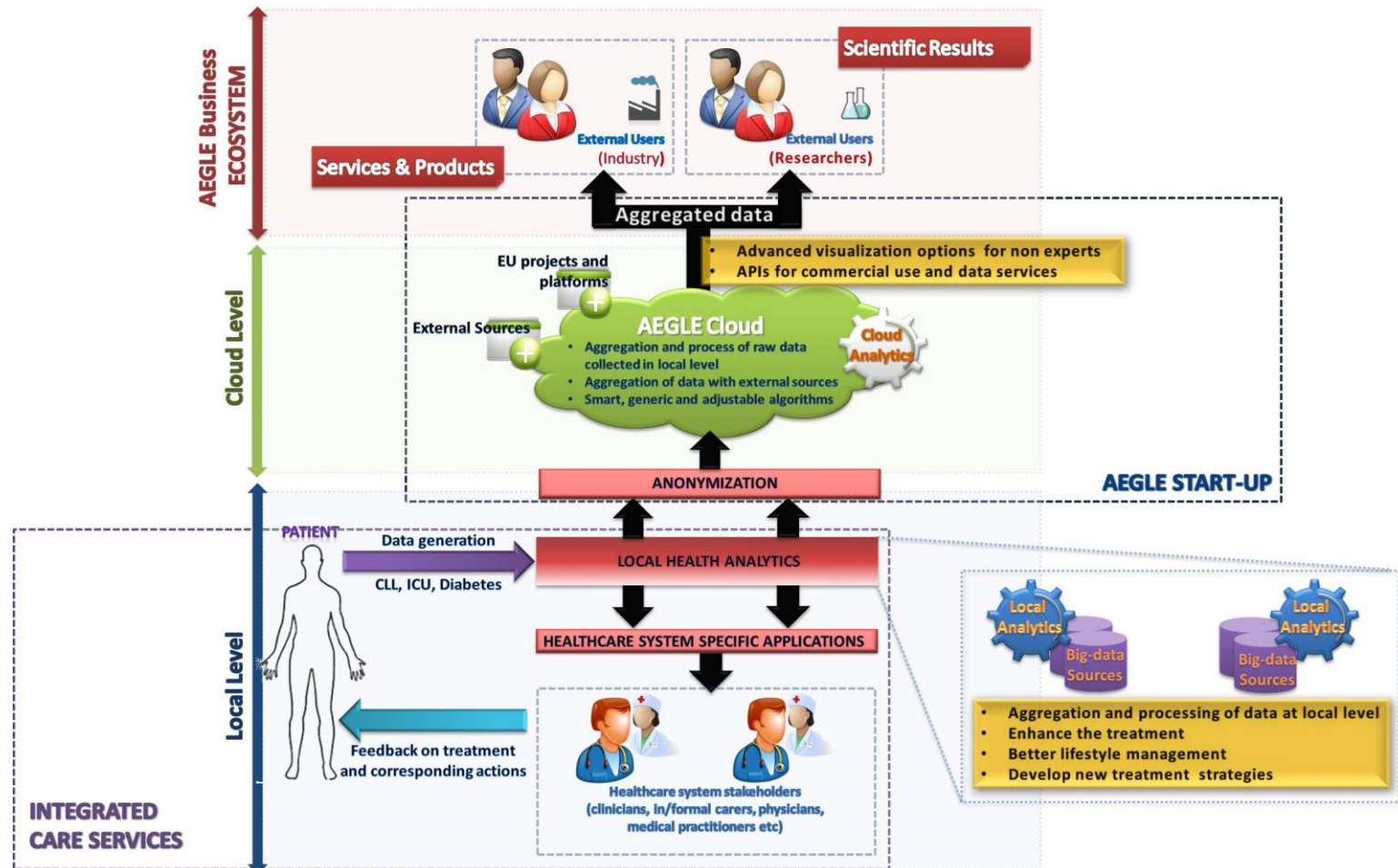

The AEGLE applications

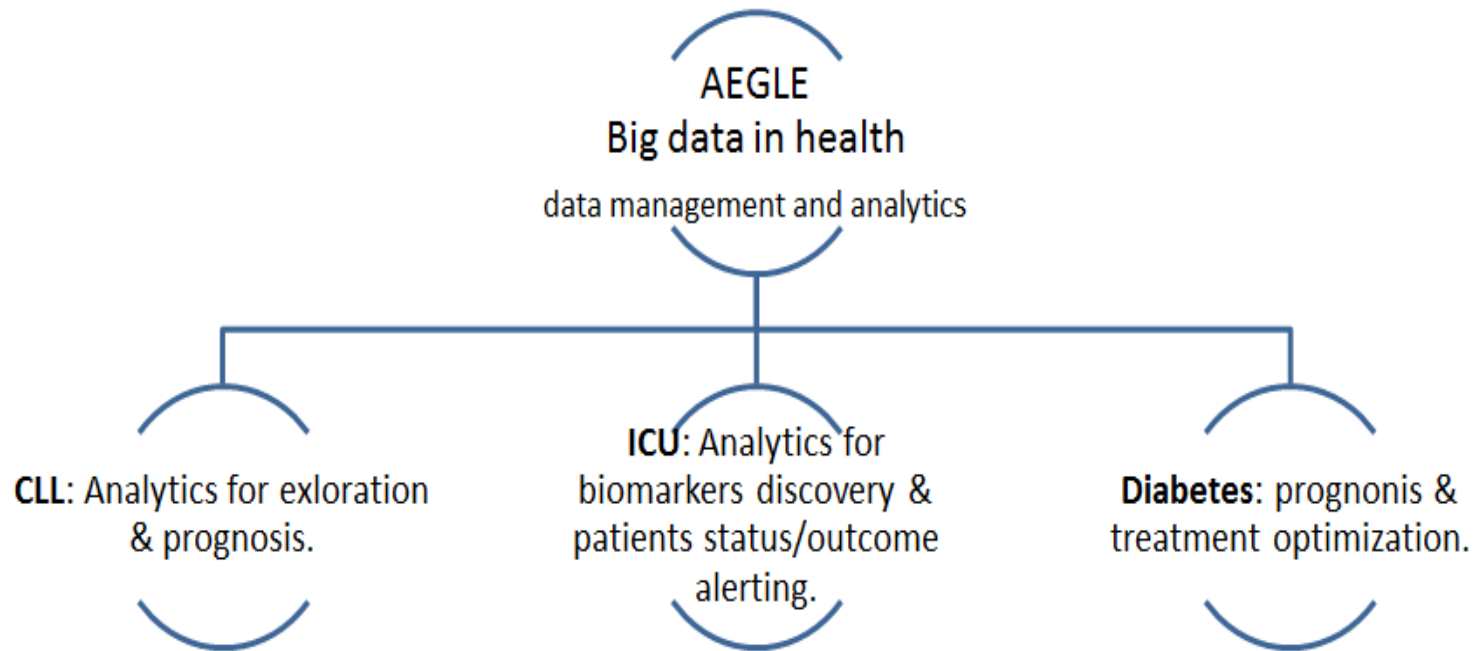

AEGLE Overall system design

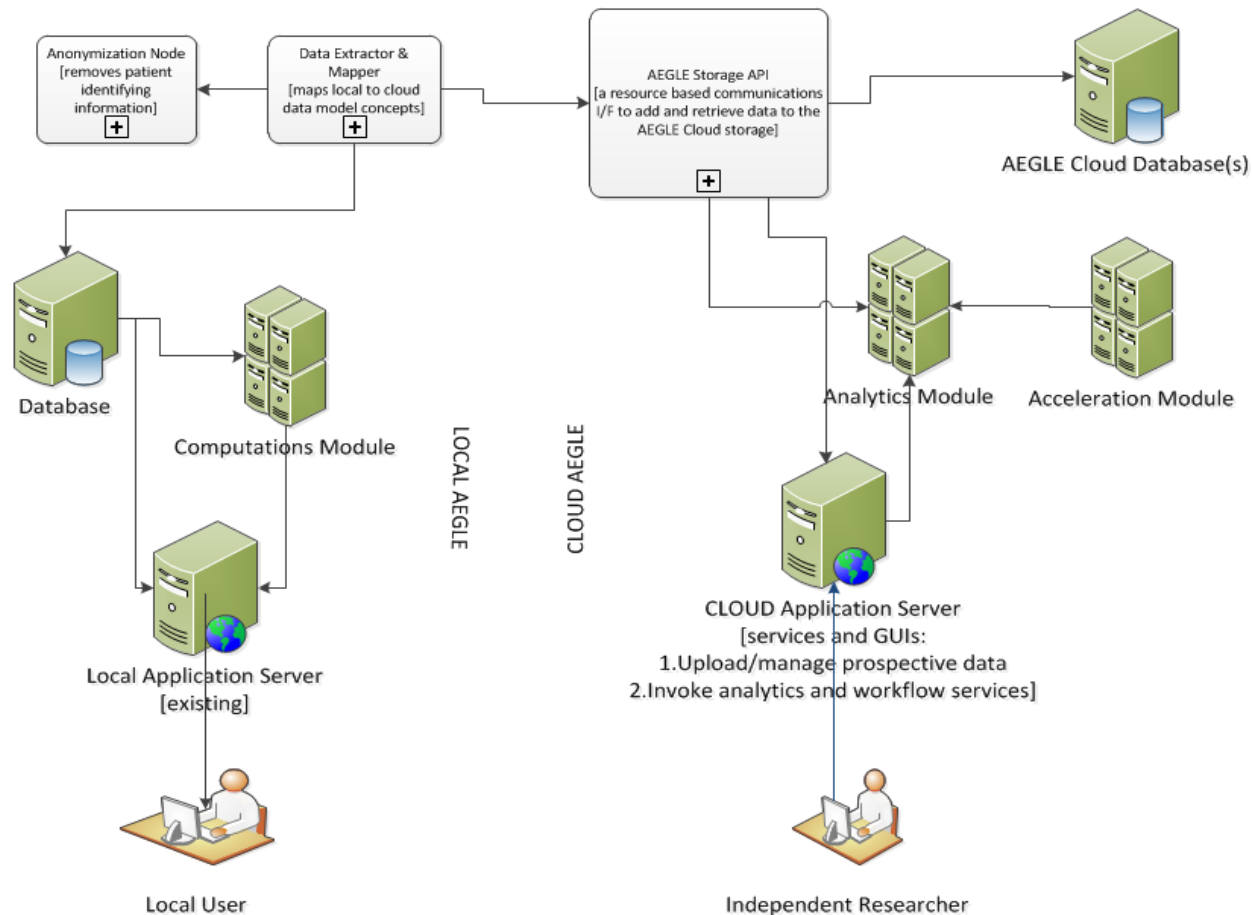

AEGLE Local to cloud

- **FedEHR** anonymiser from GNUBILA
- 4 major data mining techniques to identify personal information and treat it accordingly
- Data Extractor & Mapper (ETL by Apache camel)

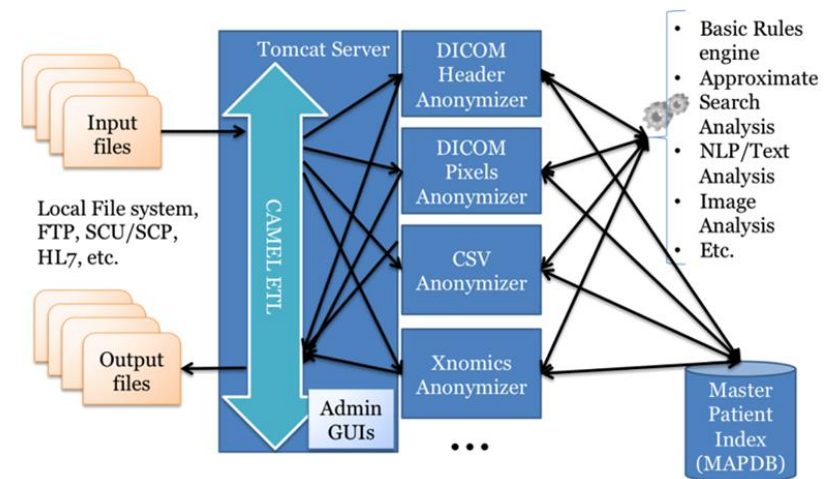

AEGLE Cloud Storage API

- **FedEHR Big Data Federation Service**
- The FedEHR characteristics are the following:
- Flexible data model – archetype-based
 - Modification at runtime supported
 - BI integrity constraints encoded
 - Multi-modal and multi-site
- Distributed or Centralized architecture
 - Fit client’s architecture requirements
 - Hybrid cloud integration
- Graph-oriented database engine
- Standard SOAP & REST APIs
- Custom client applications

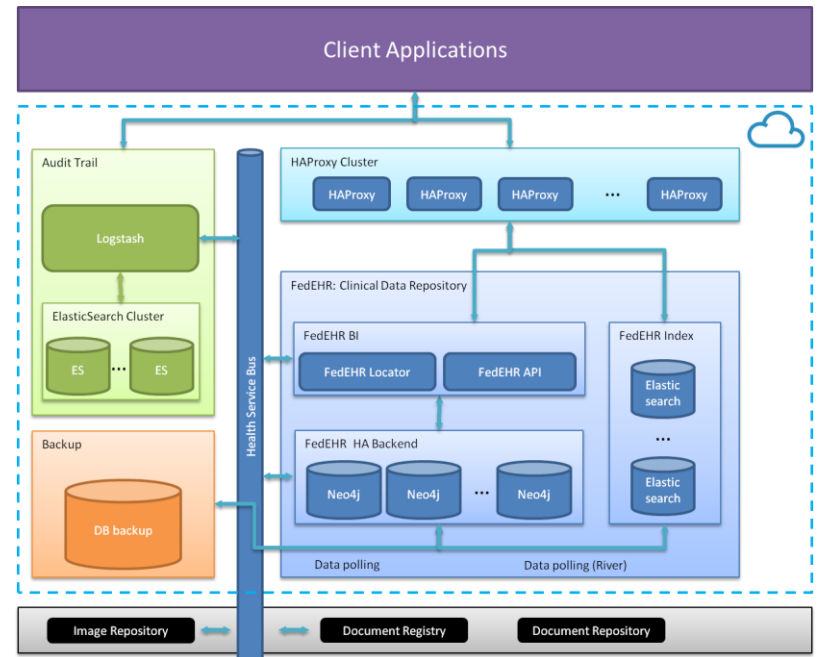

AEGLE Cloud Analytics

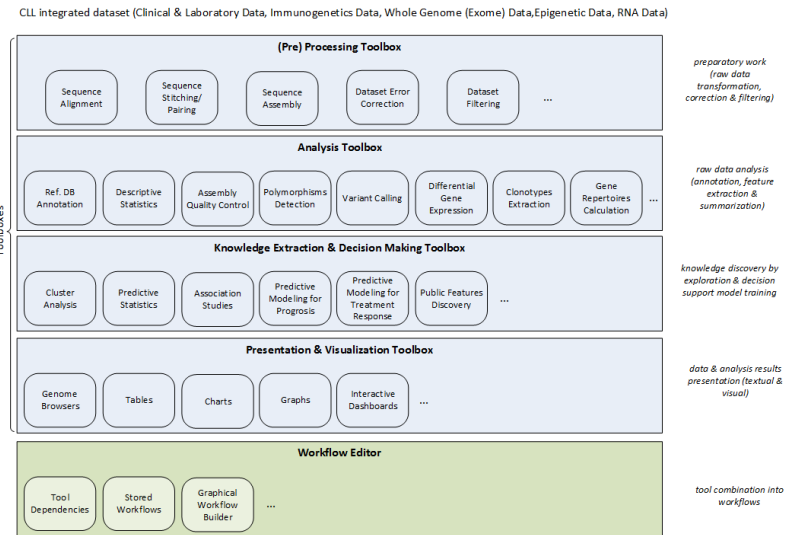
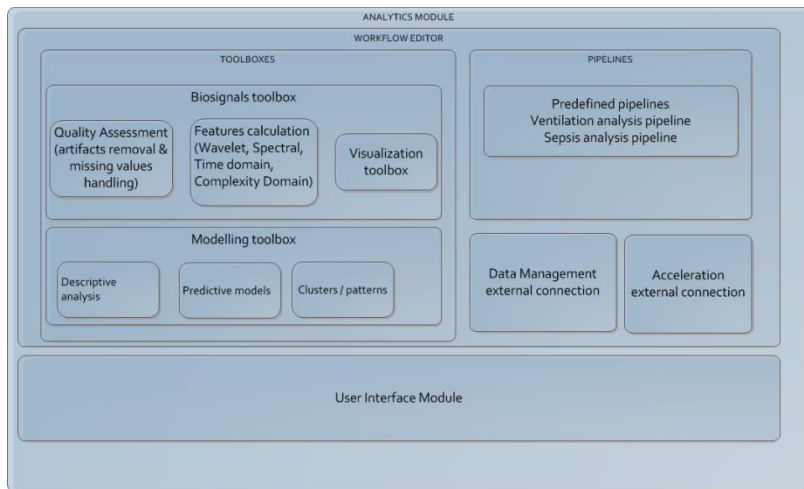

ICU and CLL toolboxes abstraction.

Why do we need large data sets in coordinated care?

- The growth in health expenditures is driven by multiple factors. One critical factor is the rising incidence of chronic diseases, which account for 75% of the cost of medical care.
- Chronic patients have higher rates of unnecessary hospital admissions and take many medications to manage their conditions.
- Traditional fee-for-service payment models that pay for treatment transactions are ill-suited for serving patients that require close monitoring and treatment tweaking and must be managed in a coordinated fashion.
- The traditional providers of chronic disease management, primary care physicians, only touch patients intermittently and rely on patients themselves to comply with care plans and lifestyle recommendations.

Why do we need large data sets in coordinated care?

- Need for coordinated care
 - Patients with complex chronic diseases and multiple comorbidities may see on average 11 different doctors a year, creating major challenges for communication, information sharing, reconciliation of care plans and patient follow-up
 - Another key driver of high health care expenditures is waste. Studies found that roughly 30 percent of health care spending is wasted due to unnecessary or poor quality care and a general lack of coordination between providers.
 - New incentives are required to increase accountability and foster a continuous improvement culture focused on longitudinal patient outcomes.
 - In addition, all participants in the health care system – patients, doctors, hospitals, health systems, long-term and post-acute care providers, insurers and government agencies – need to have usable information available to make informed decisions.

HEARTCYCLE CHF Monitoring and Intervention Functionalities

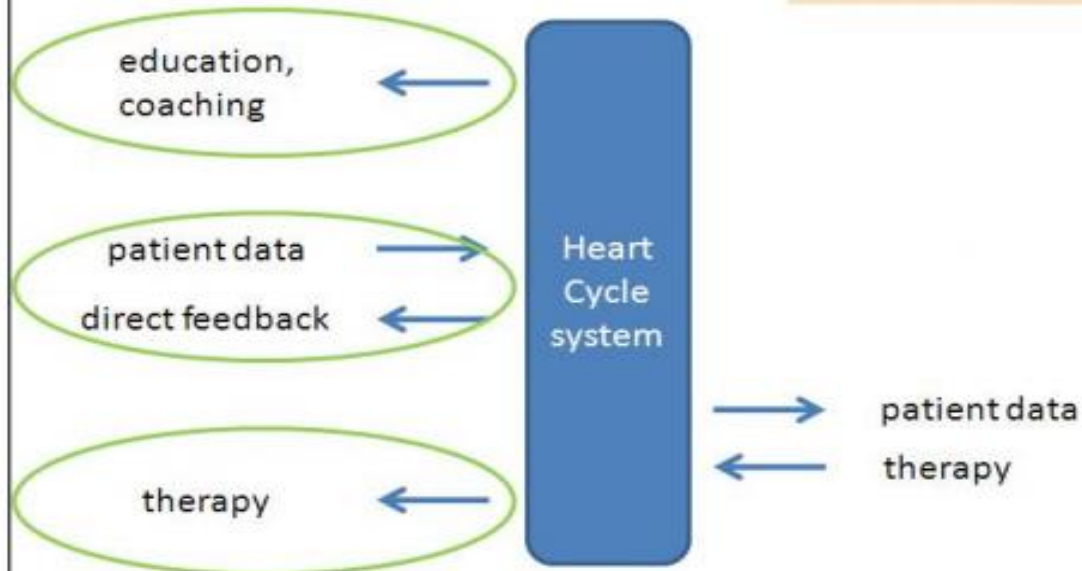

WELCOME project – Multimorbid patient integrated care model

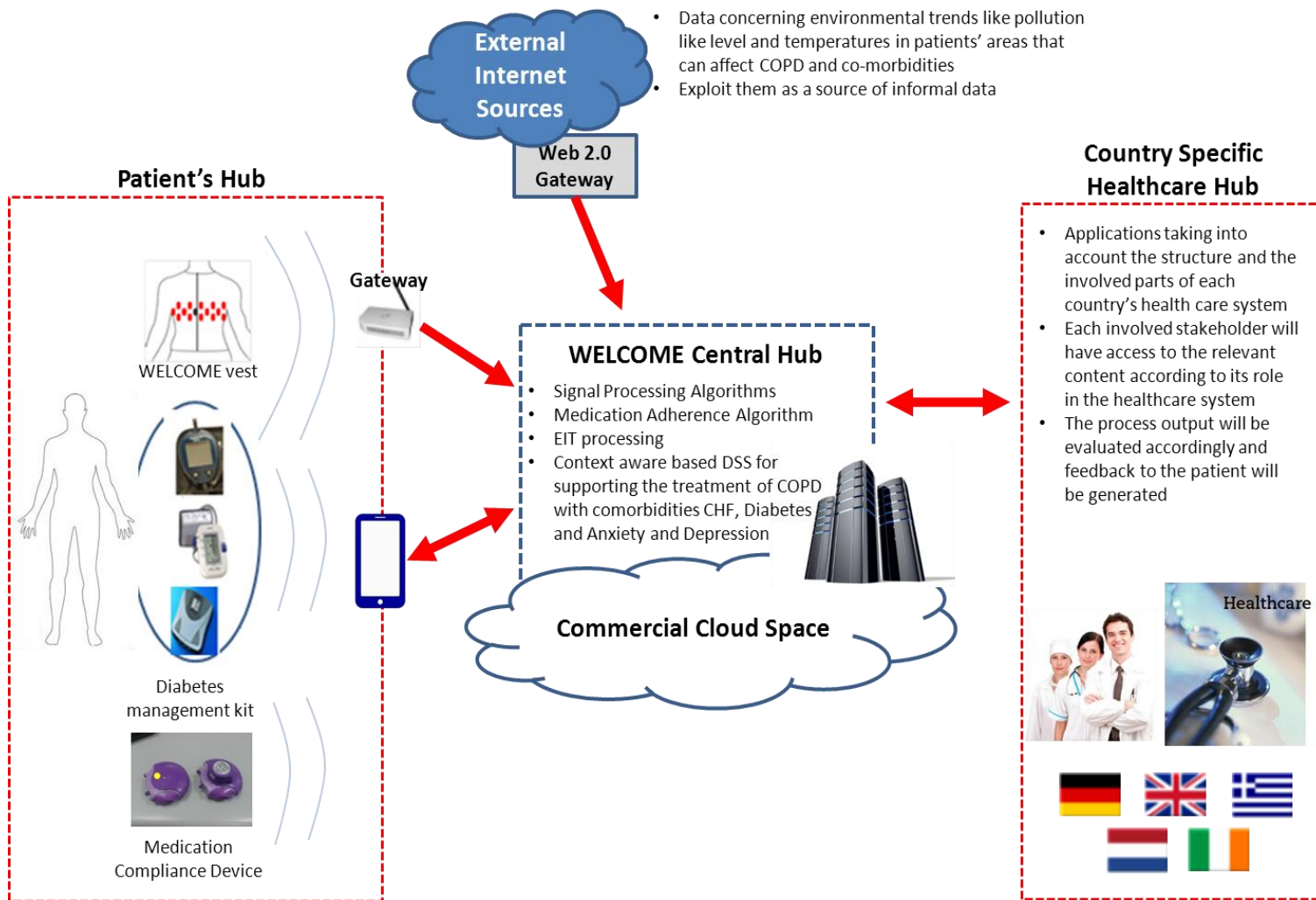

Biosensors recording evolution enabling higher dimensionality in biodata acquisition

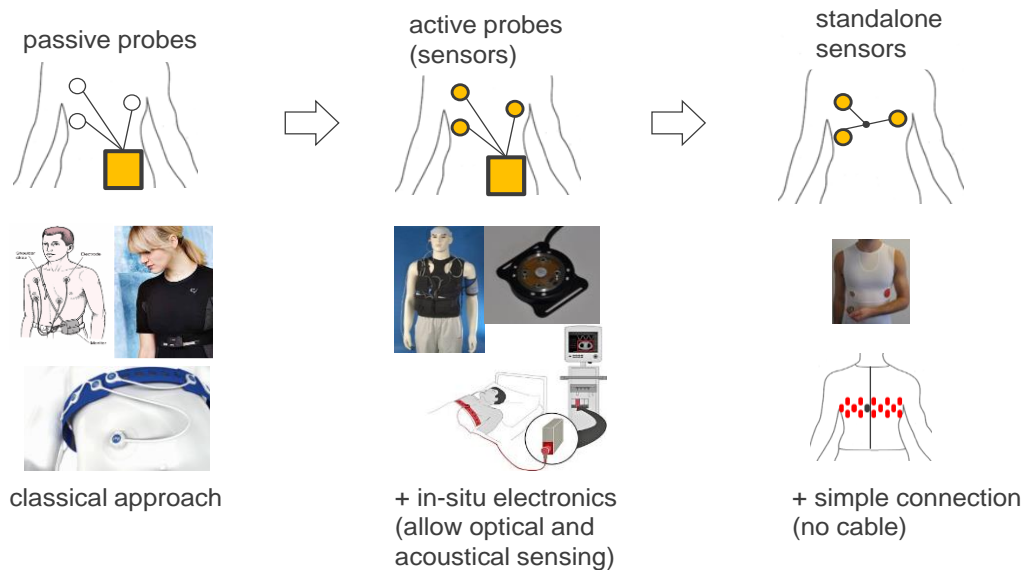

state-of-the-art sensors (developed by CSEM)
 top: standalone sensor for one-lead ECG
 bottom: active probe for ECG and SpO2 (at chest)

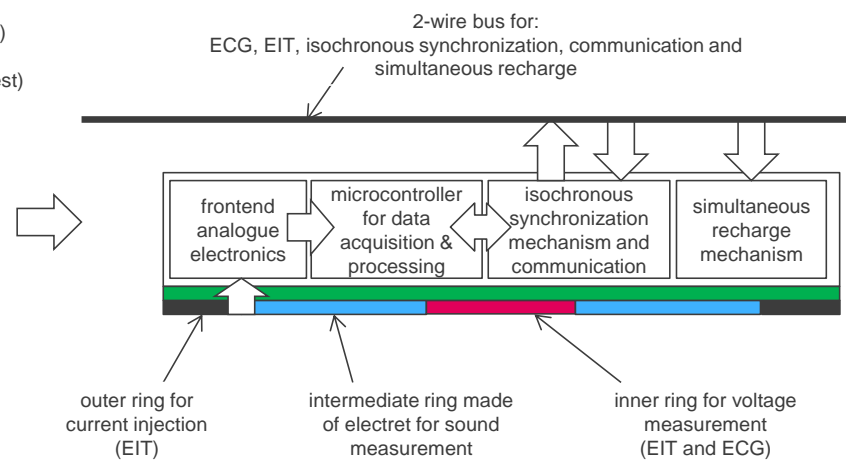
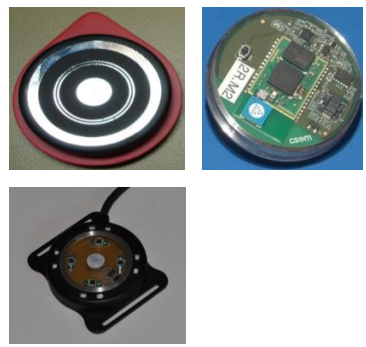

SPLENDID project – Prevention and coaching of healthy young people

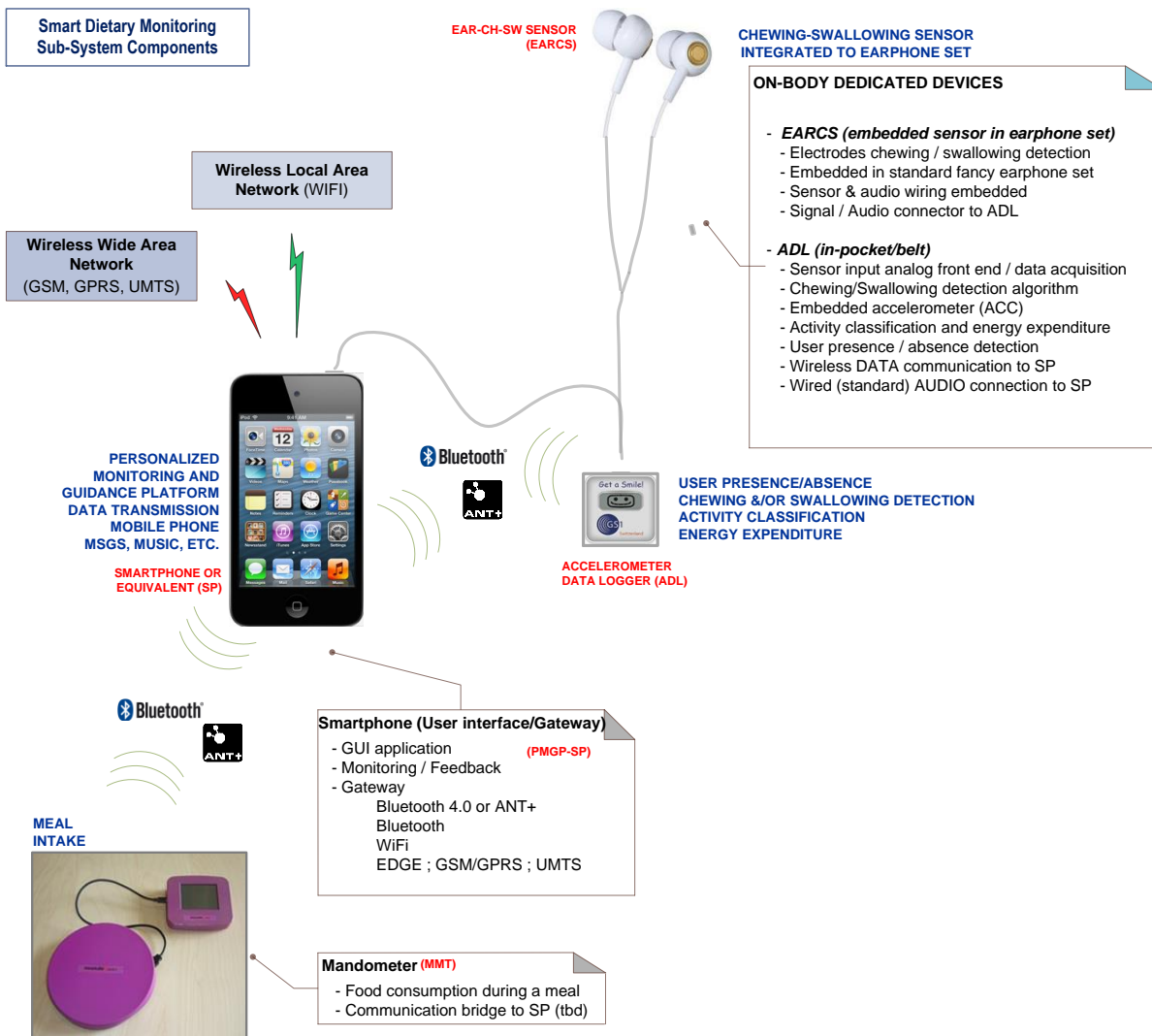

Conclusions

- Big data are a function of sensor recording capacity, ICT barriers (e.g. network availability, communication means), energy scavenging, knowledge management & engng, patient empowerment, regulatory & ethical constraints, adaptability of clinical trial protocols, integration of social network information and semantics, regional KPIs, virtual physiological human models, computational resources.....
- We are currently still in the beginning of a long journey to the unknown world of big data
- We need tools and means to be able to navigate so as to achieve efficient CDSS, patient adherence, personalized health and production of solid evidence based medicine

Big Data in Health in Greece

- The situation is becoming mature
- There can be big Data integration at the hospital level (e.g. imaging, clinical data, lab data, biological data, biosignals)
- There are possibilities for Big Data from tele-monitoring studies and medication clinical trials
- Big Data related with prevention and rehab using among others social networks and pHealth
- It is time to begin

Acknowledgements

EU-funded Projects

- **AEGL**E (An analytics framework for integrated and personalised health services in Europe) 2015-2018
- **WELCOME** (Wearable Sensing and Smart Cloud Computing for Integrated Care to COPD Patients with Comorbidities) 2013-2017
- **SPL**ENDID (Personalised Guide for Eating and Activity Behaviour for the Prevention of Obesity and Eating Disorders) 2013-2016
- **ITECH** (Roadmap for Research and Innovation in Health Technology) 2013-2016
- **ACT** (Advancing Care Coordination and Telehealth Deployment Programme) 2013-2016
- **PIPAVIR** (Detection of Persistent Infections by human Papillomaviruses) 2012-2015
- **CLOUD4ALL** (Cloud platforms Lead to Open and Universal access for people with Disabilities and for All) 2011-2015
- **UNIVERSaal** (UNIVERSal open platform and reference Specification for Ambient Assisted Living) 2009-2014
- **AAL-169 REMOTE** (Remote health and social care for independent living of isolated elderly with chronic conditions) 2009-2011
- **PSIP** (Patient Safety through Intelligent Procedures in Medication), 2008-2011
- **HEARTCYCLE** (Compliance and effectiveness in HF and CHD closed-loop management), 2008-2013
- **VPH** (Virtual Physiological Human Network of Excellence), 2008-2012